

Ultimaker

The fast, easy to use, Open-source 3D printer

Assembly instructions

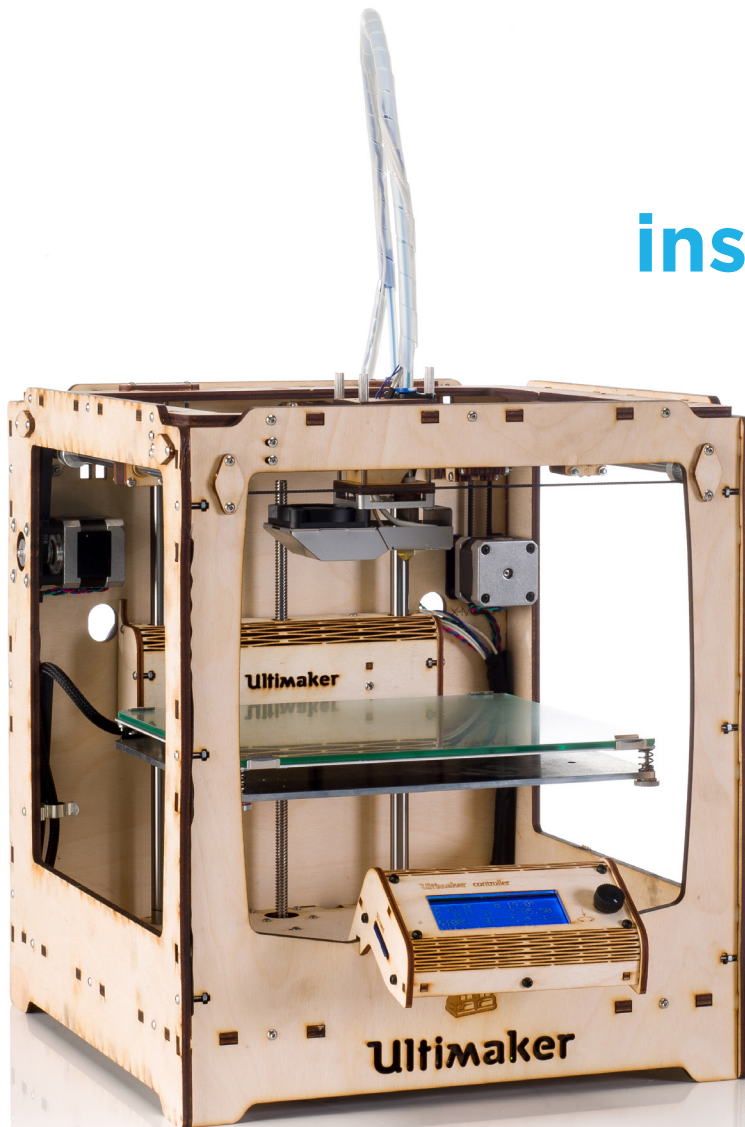

English version 2.0

Ultimaker Original+ Assembly manual

Dear customer,

Thank you for purchasing the Ultimaker Original+ DIY kit and welcome to our community!

This assembly manual will guide you through the build process step by step. During the excitement of the build process you learn more and more. This will help you understand the workings of a 3D printer even better and give you the opportunity to get the most out of your Ultimaker.

Besides this assembly manual there's also a user manual available online:
www.Ultimaker.com/pages/support/manuals

Meet other Ultimaker users at our community forum: www.Ultimaker.com/forum

Visit YouMagine for fun projects and free printable models: www.youmagine.com

Happy building and printing and we'll be in touch!

Team Ultimaker

Contact information

We would love to hear from you. We are easy to reach and enjoy answering all your questions. Technical assistance, sales enquiries or general information, we are there for you. Find the information below to contact us.

General	info@Ultimaker.com
Support	support@Ultimaker.com
Sales	sales@Ultimaker.com
Marketing/PR	pr@Ultimaker.com
Phone	+31 (0)345 712 017

Meet us online at:



Table of contents

1	Introduction	5
1.1	Product description	5
1.2	Used symbols	5
2	Technical specifications	6
2.1	General product specifications	6
2.2	Environmental conditions	6
3	Precautions and safety instructions	7
4	Preparation before assembling	8
4.1	Engraving	8
4.2	Sanding	8
5	What to expect reading the assembly instructions	8
5.1	Structure of the assembly instructions	8
5.2	Different sides of the Ultimaker Original+	8
6	Assembling the Ultimaker Original+	10
6.1	Assembling the frame	10
6.1.1.	Step 1: Inserting the ball bearings	11
6.1.2.	Step 2: Mounting the limit switches	12
6.1.3.	Step 3: Assembling the X and Y motor	16
6.1.4.	Step 4: Preparing the BOTTOM panel	19
6.1.5.	Step 5: Assembling the 'cube'-shaped frame	20
6.1.6.	Step 6: attaching various parts	26
6.2	Assembling the X/Y axes	28
6.2.1.	Step 1: Assembling the FRONT, BACK, RIGHT, LEFT slider blocks	29
6.2.2.	Step 2: Attaching the claws	30
6.2.3.	Step 3: Mounting the caps	32
6.2.4.	Step 4: Mounting the axes	36
6.3	Assembling the extrusion head	42
6.3.1.	Step 1: Assemble the extrusion head housing	43
6.3.2.	Step 2: cooling fan assembly	51
6.3.3.	Step 3: attaching the housing on the XY frame	53
6.3.4	Step 4: Alligning the X-Y Switches.	57



6.4	Assembling the Z stage	58
6.4.1.	Step 1: Assembling the Aluminium base plate.	59
6.4.2.	Step 2: Assembling the Heated bed PCB	61
6.4.3.	Step 3: Connecting the PCB to the Baseplate	63
6.4.4.	Step 4: finishing the Z stage assembly	65
6.4.5.	Step 5: installing the Z stage in the machine	68
6.4.7.	Step 7: greas it up	70
6.4.8	Step 8: Aligning the Z-stage	71
6.5	Assembling the material feeder	72
6.5.1.	Step 1: drive mechanism main body assembly	73
6.5.2.	Step 2: drive bolt assembly	75
6.5.3.	Step 3: clamp assembly	77
6.5.4.	Step 4: attaching the feeder to the machine	82
6.5.5.	Step 5: assemble the filament holder	82
6.6	Mounting the electronics circuit board	85
6.6.1.	Step 1: mounting the electronic circuit board	86
6.6.2.	Step 2: connecting the heater and Heated Bed	87
6.6.3.	Step 3: connecting the print head electronics	89
6.6.4.	Step 4: connecting the limit switches	89
6.6.5.	Step 5: connecting the motors	89
6.6.6.	Step 6: mounting the electronics cover	90
6.6.7.	Step 7: strain relief	91
6.7	Assembling and connecting the UltiController	92
6.7.1.	Step 1: assembling the UltiController	93
6.7.2.	Step 2: connecting the controller	95
6.7.3	Step 3: Checking and aligning the Top-Z limit switch	96
7	Usage of the Ultimaker Original+	98
7.1	Using the Ultimaker Original+ for the first time	99
7.1.1.	Slicer software	99
8	Annex	
8.1	Safety guidelines for the ultimaker original +	101



1 Introduction

1.1 Product description

The parts of the Ultimaker Original+ can only be used for assembling the Ultimaker Original+. An assembled Ultimaker Original+ can only be used for 3D printing of products.

Ultimaking B.V. cannot be held liable for any damage caused by improper, incorrect or unwise use. Please read this manual completely and make sure you understand it.

1.2 Used symbols

 **Warning!** A warning indicates the risk of (serious) damage to the user or the product if the user does not carry out the procedures with care.

 **Caution!** A comment makes the user aware of possible problems.

 **Notice:** A notice makes the user aware of convenient functions and additional options.



2 Technical specifications

2.1 General product specifications

Product description

Name:	Ultimaker Original+
Model/type:	Revision 4
Year of production:	2014
Dimensions (W x D x H)	357 x 342 x 388mm
Mass	9 kg

Technical specifications

Power source	110V or 230 V
Operating system:	Windows, MAC and Linux
Speed:	Max. head travel speed between 30mm/s - 300mm/s.
Accuracy:	Positioning < 0.05mm
Build volume (X,Y,Z):	210 x 210 x 205mm
Technology:	FFF (Fused Filament Fabrication)
Ambient Operating Temperature:	15° - 32° C
Storage Temperature:	0° - 32° C

2.2 Environmental conditions

The Ultimaker Original+ can only be used in a dry environment. The product cannot be used in a humid environment and in an environment with lots of UV light. Usage in other environments can result in unwanted effects on the performance of the product.



3 Precautions and safety instructions



Only use original accessories from the manufacturer.



The product should only be used for applications as described by the manufacturer. The manufacturer cannot be held liable for damage resulting from errors or unintended use of the device.



Do not install the product outdoors or in any place where it might become wet.



Do not install the product in any place that might be exposed to extreme heat or cold.



Keep the product out of reach of children.



Disconnect the device from all power sources before cleaning it.



Remove the adapter from the power outlet during storms, lightning and whenever the product will not be used for a longer period of time.



Install the product as indicated in this manual. If in doubt, consult a recognized technician and always take account of local installation codes and regulations.



The product should be kept out of direct sunlight.



The product must not be discarded as unsorted municipal waste, it must be disposed of separately.



Find out about the options in your region for disposing of the product after use. Do not throw away electrical appliances or components, but see whether the product (components) can be turned in, recycled or reused.



4 Preparation before assembling

4.1 Engraving

All panels are marked with the side they belong to.

For all the panels except the FRONT panel and the BOTTOM panel, the engraving faces inwards. The FRONT panel has the “Ultimaker” engraving facing outward. The BOTTOM panel has the engraving facing downward.

4.2 Sanding

Before starting the assembly, you may want to sand the panels slightly to remove any burn marks/blemishes from the laser cutting process. You can also paint or stain your Ultimaker Original+. Be aware that paint will not cover the brown cutting edges very well.

5 What to expect reading the assembly instructions

5.1 Structure of the assembly instructions

Before assembling the Ultimaker Original+, separate sub assemblies have to be built. The description of every sub assembly in this manual will contain:

- An overview of the needed tools;
- An estimation of the needed time to built the sub assembly;
- The steps;

Every step in this manual will be described using the following structure:

- Cautions and warnings (if applicable);
- The needed parts;
- The actions to perform the step.

To make this manual easy to understand, images are used as much as possible.



5.2 Different sides of the Ultimaker Original+

In this manual, you will read about FRONT side, BACK side, LEFT side, RIGHT side, TOP side and BOTTOM side. In image 1 these terms are clarified.

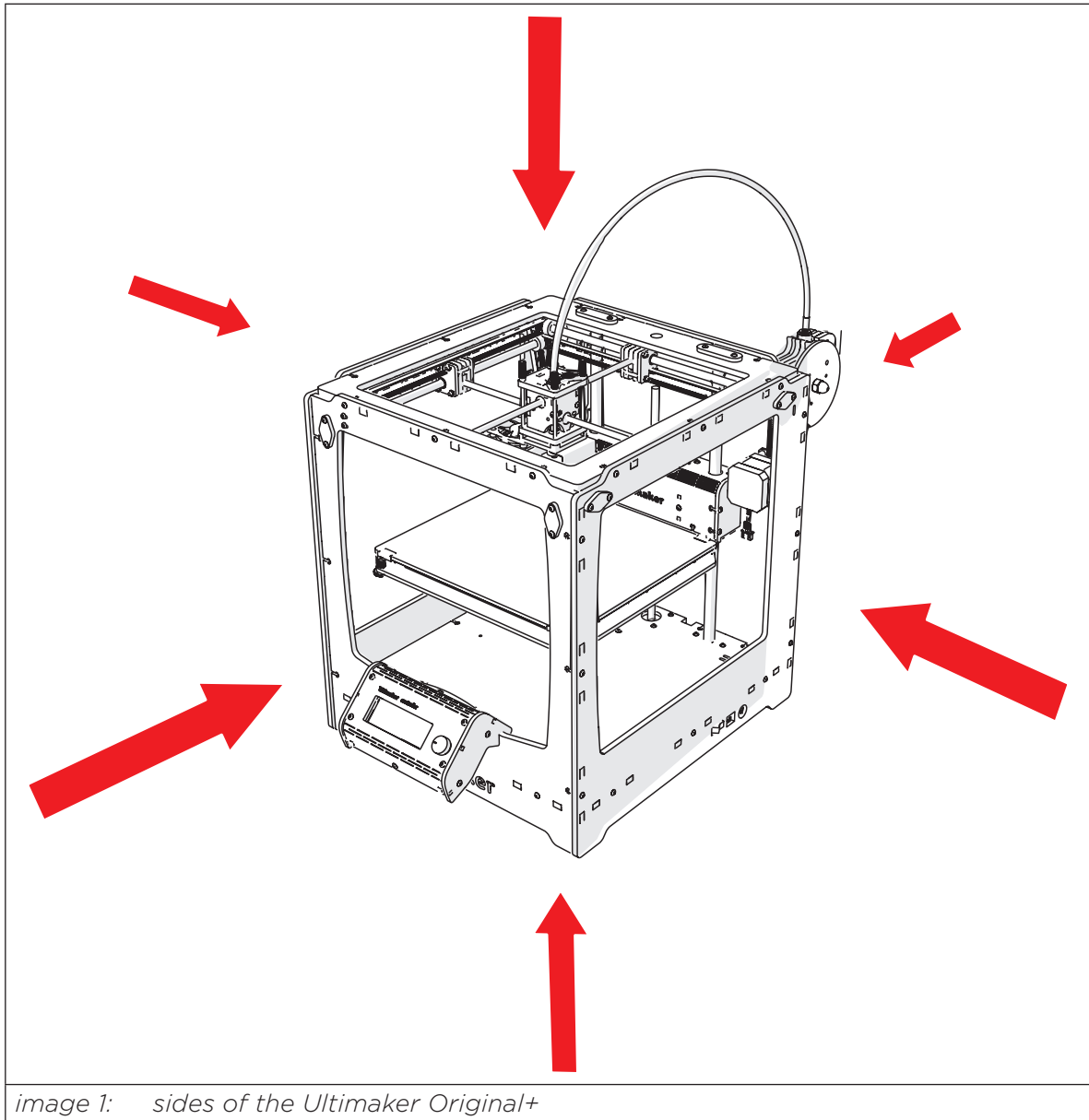

6 Assembling the Ultimaker Original+

6.1 ASSEMBLING THE FRAME

WHAT YOU'LL NEED TO BUILD THIS SUB ASSEMBLY.

Time:

about 60 to 90 minutes

Tools:

hex key screwdriver (1,5mm)

hex key wrench (2mm)

5.5mm (M3) socket wrench or pliers

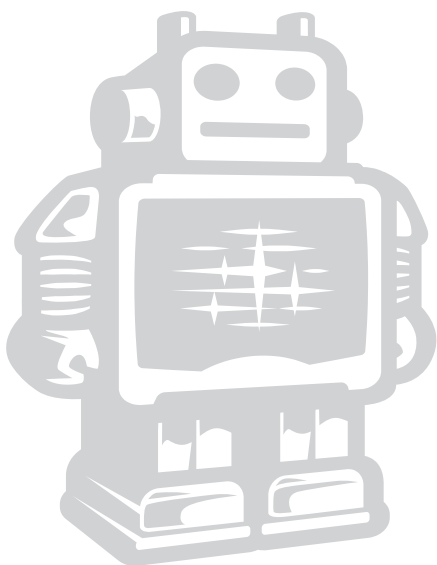

6.1.1. Step 1: Inserting the ball bearings

The following parts are needed in this step.

Letter	Description	Qty.
A	FRONT panel (1002)	1
B	LEFT panel (1004)	1
C	RIGHT panel (1005)	1
D	BACK panel (1003)	1
E	ball bearings 8mm (1021)	8

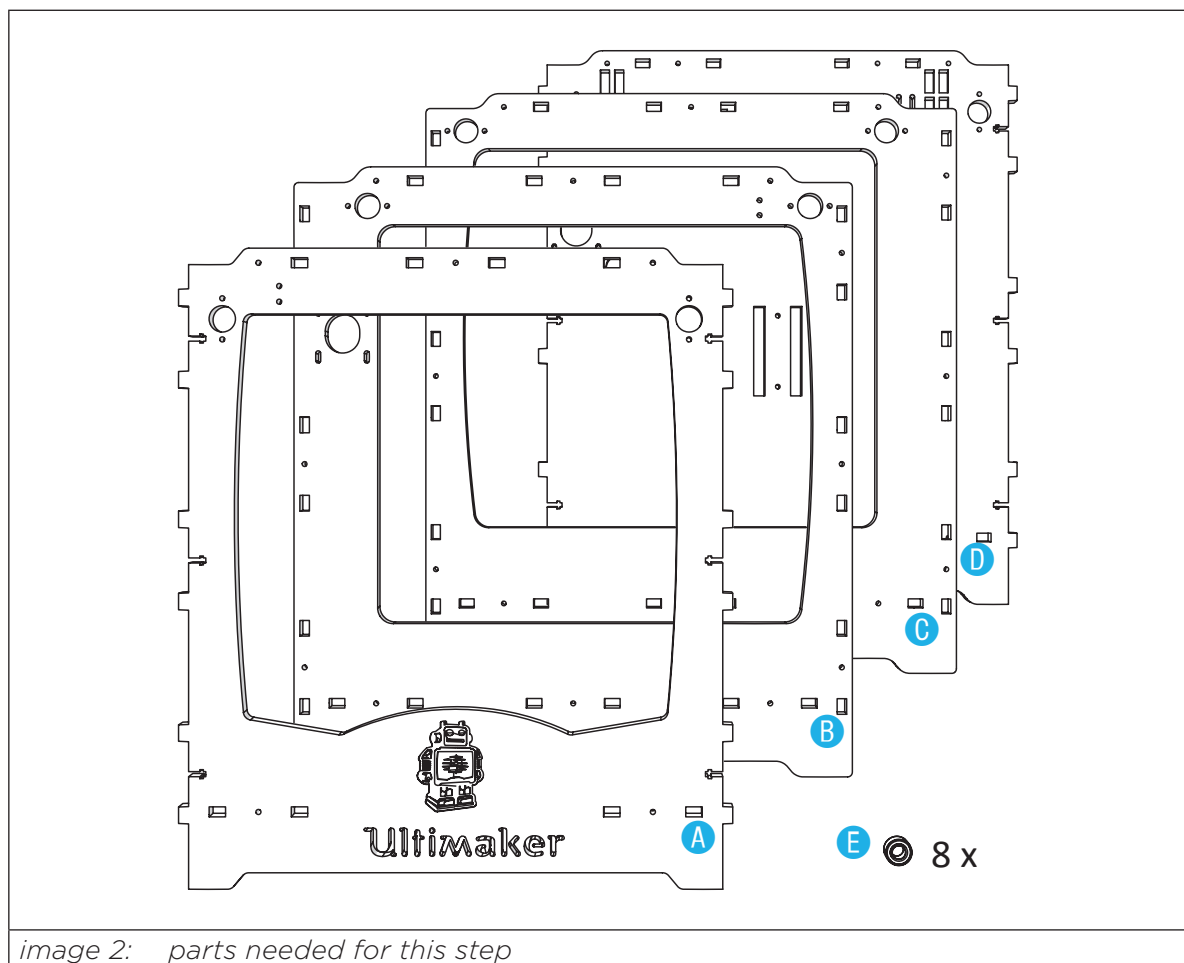

Every panel needed for this step has two corresponding holes.
To place the ball bearings, perform the following actions:

1. Get a panel.
2. Place the ball bearings.
Make sure you place the ball bearings as deep as shown in image 3.
3. Repeat action 1 and action 2 for all panels.



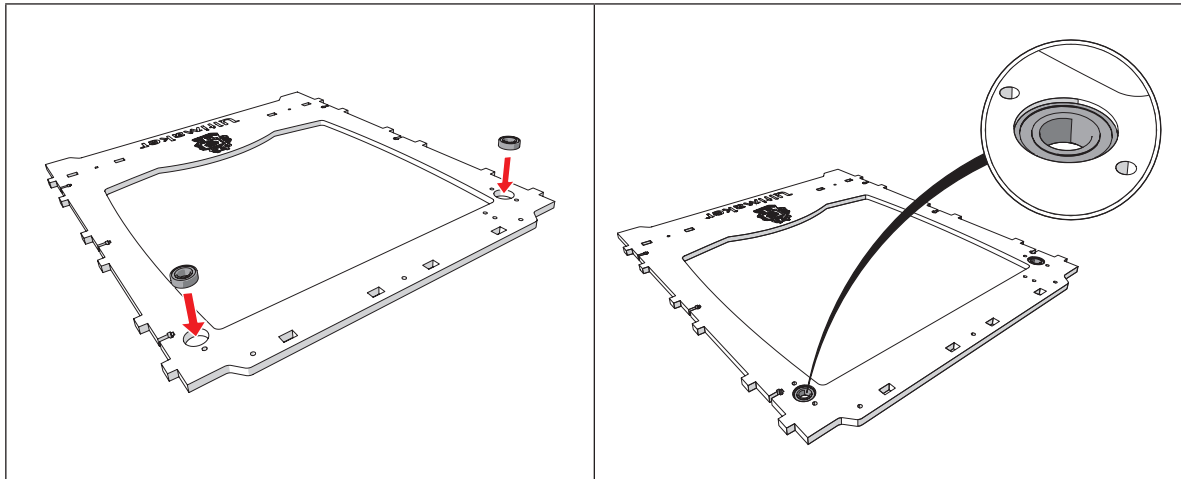

image 3: placing the ball bearings into the panel

6.1.2. Step 2: Mounting the limit switches



Warning! Do not strain the tapped thread on the inside of the switch housing by putting a lot of force on the bolts. All limit switches are pre-tapped, you can fasten them directly with M3 bolts, no nuts required here!



Caution! Note that all wires of limit switches need to be twisted, see image 4.

The following parts are needed in this step.

Letter	Description	Qty.
A	FRONT panel (1002)	1
B	LEFT panel (1004)	1
C	BACK panel (1003)	1
D	RED wired limit switch (1026)	1
E	BLUE wired limit switch (1026)	1
F	BLACK wired limit switch (1023)	1
G	bolts M3 x 12mm (1203)	4
H	bolts M3 x 16mm (1204)	2
I	washers (1201)	2



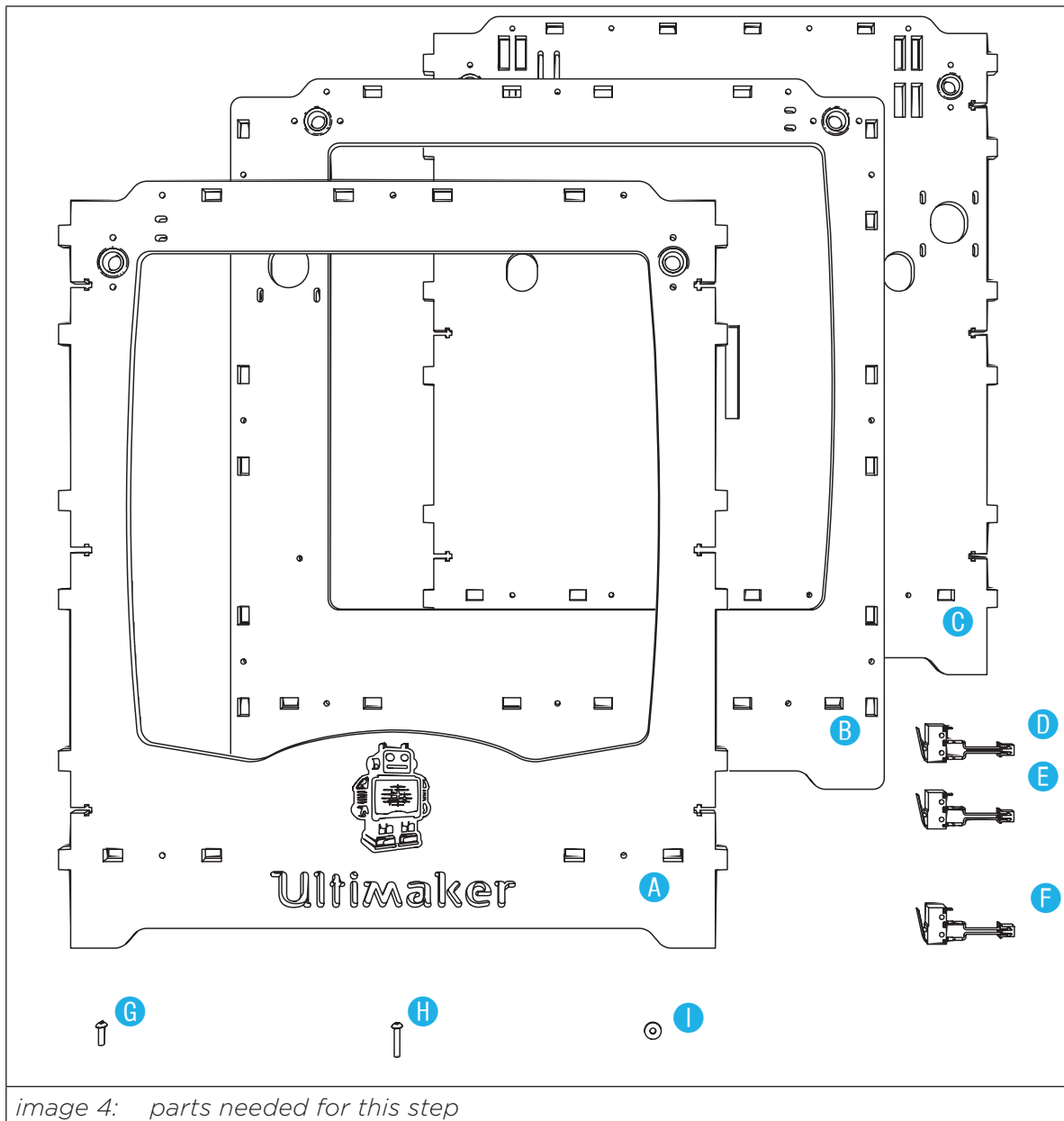

image 4: parts needed for this step

The orientation of the limit switches are engraved on the panels, except for the FRONT panel.

The machine has 3 limit switches:

- 1 with BLUE wires
- 1 with RED wires
- 1 with BLACK wires



To mount the BLUE wired limit switch, perform the following actions:

1. Place the BLUE wired limit switch with the lever pointing upward as shown in image 5.
2. Attach the BLUE wired limit switch with two bolts M3x12mm.

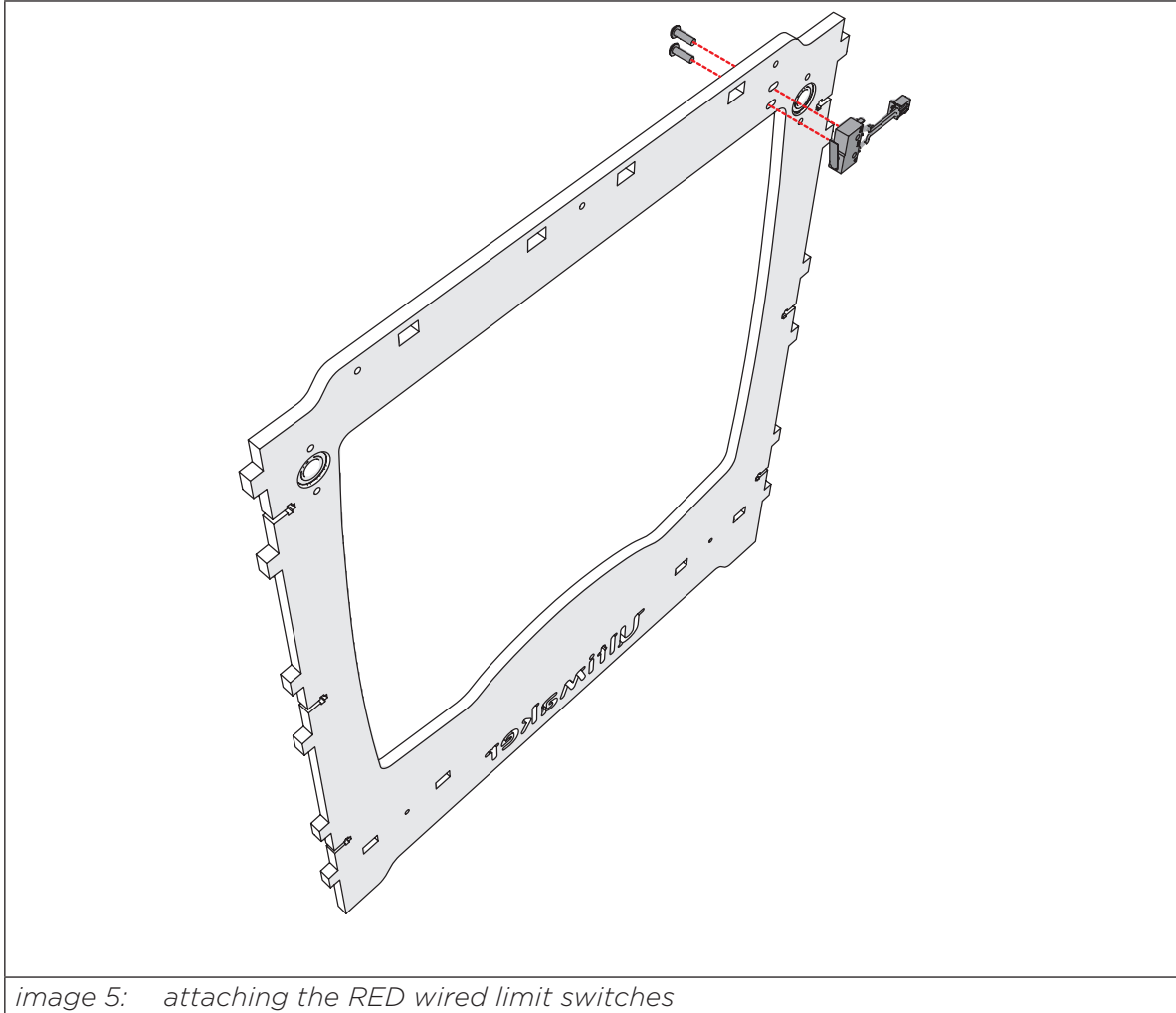

image 5: attaching the RED wired limit switches

To attach the RED wired limit switch, perform the following actions:

1. Attach the RED wired limit switch with the lever pointing downwards as shown in image 6.
2. Attach the RED wired limit switch with two bolts M3 x 12mm.



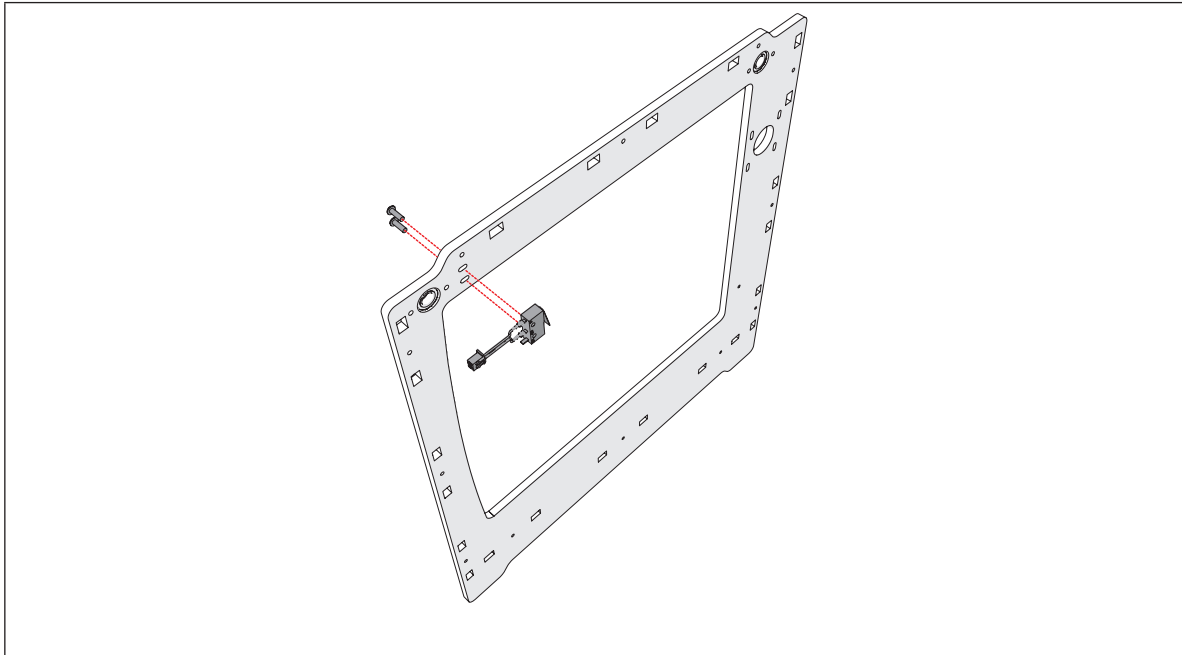

image 6: attaching the BLUE wired limit switch

To attach the BLACK limit switch , perform the following actions:

1. Attach the BLACK limit switch as shown in image 7.
- i** Fine tuning the position will be described in another part of this manual.
2. Attach the BLACK limit switch.
Use two bolts M3 x 16mm and two washers.

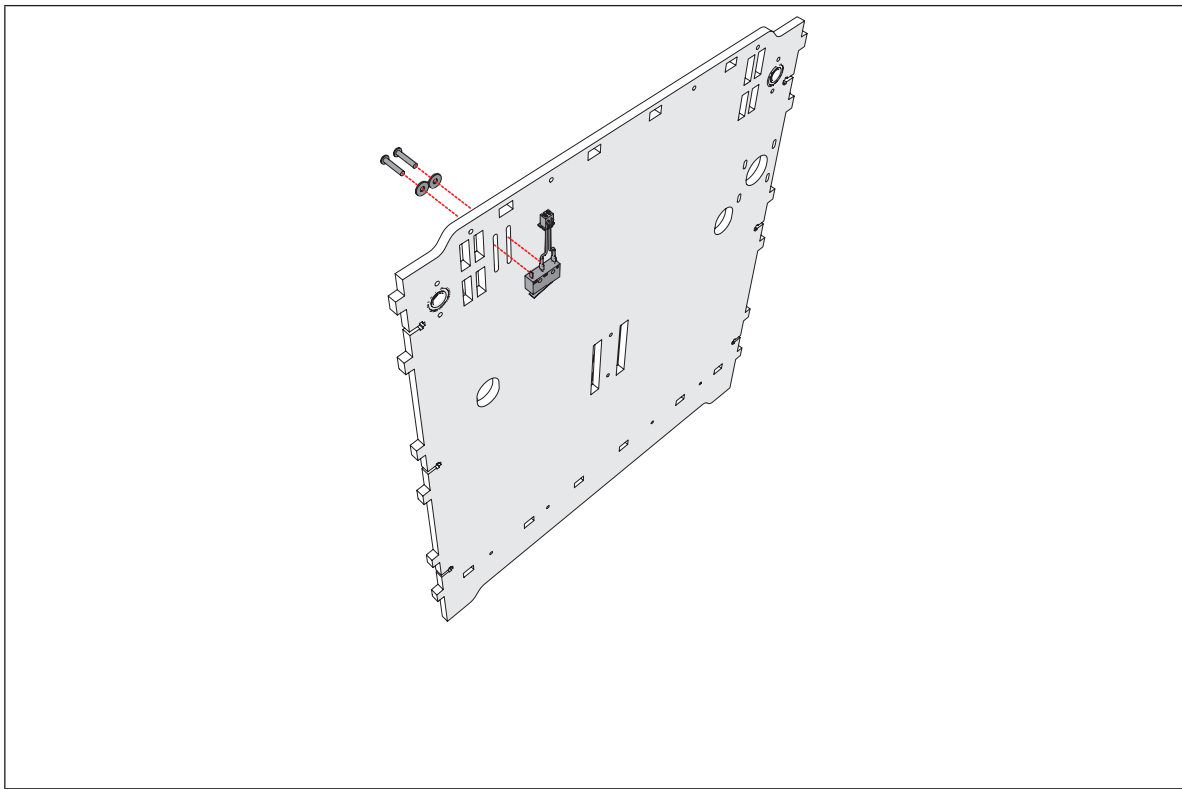

image 7: attaching the BLACK wired limit switch with LONG wires



6.1.3. Step 3: Assembling the X and Y motor

The following parts are needed in this step.

Letter	Description	Qty.
A	LEFT panel (1004)	1
B	BACK panel (1003)	1
C	X-Y Motor With the round axle (1082)	2
D	Plastic Motor spacer (1241)	2
E	M3 washers (1201)	8
F	short timing belts (1085)	2
G	pulleys with a 5mm internal diameter (1084)	2
H	bolts M3 x 25mm (1207)	8
I	Set screw M3 (1211)	2

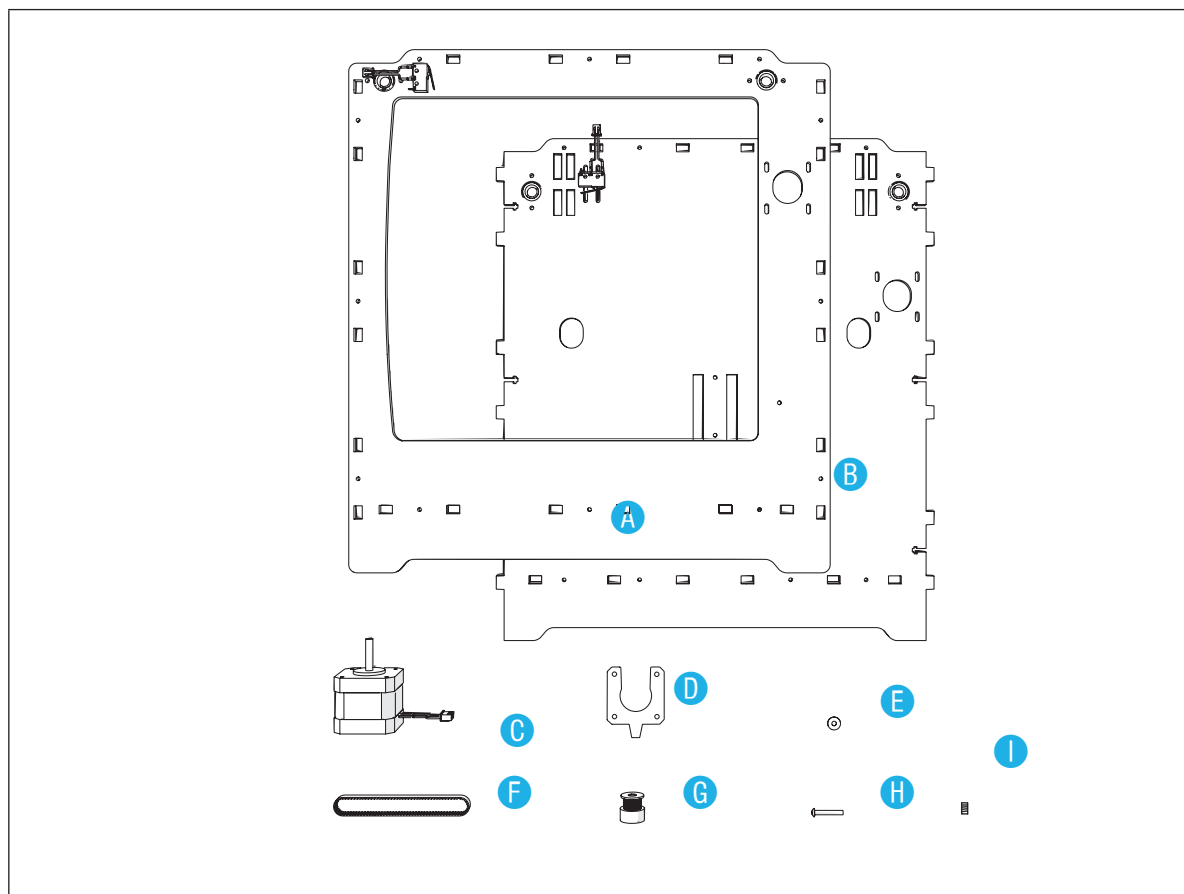

image 8: parts needed for this step



To assemble the X motor, perform the following actions:

1. Place the pulley (5mm internal diameter) on the X motor, see image 9. When placing the pulley, make sure to keep the top of the pulley flush with the top of the motor axle.

i **Notice:** Replace the set screws with the new Stainless Steel Setscrews

2. Place the timing belt around the pulley, see image 10.

3. Attach the X motor on the BACK panel with X motor engraved on the inside. See image 11.

4. Make sure to hook the cables behind the hook in the motor spacer towards the edge of the plate.

i **Notice:** Do not attach the X motor and Y motor too tight. The X motor and Y motor must be able to move up and down.

i **Notice:** Place the X motor and Y motor in position that the wires face down in direction of the text.

5. To assemble the Y motor repeat action 1-2.

6. Make sure to attach the Y motor on the LEFT panel with Y motor engraved on the inside. See image 11

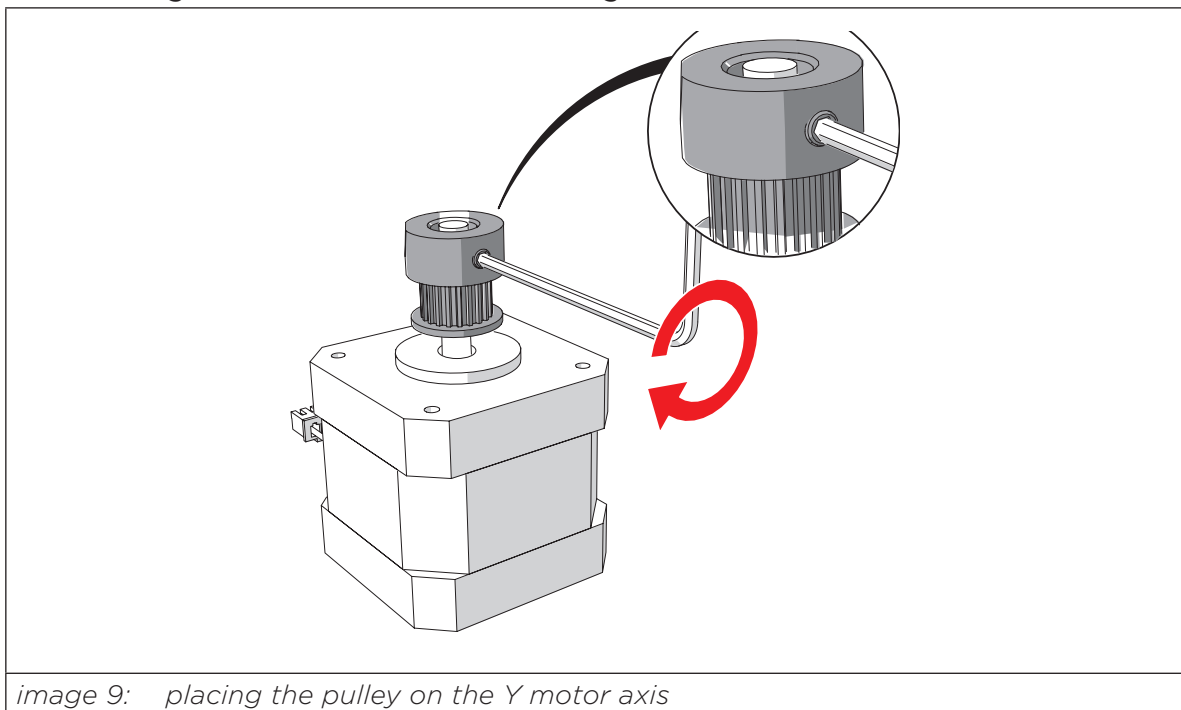

image 9: placing the pulley on the Y motor axis



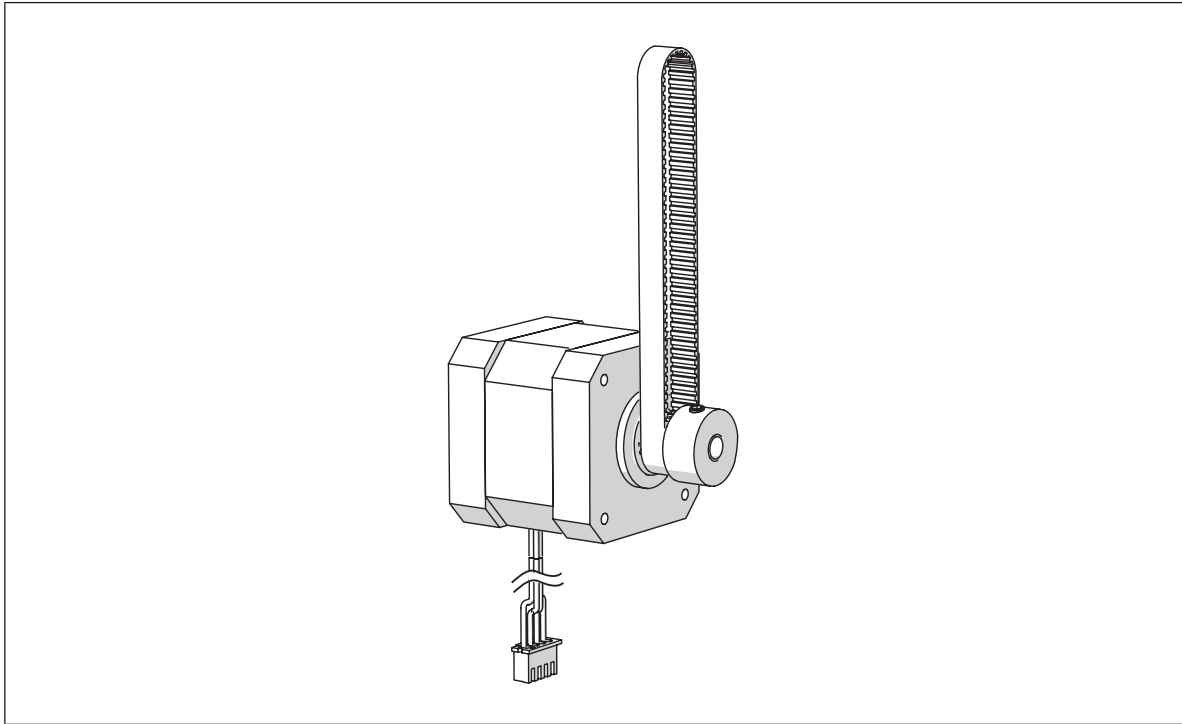

image 10: placing the timing belt around the pulley

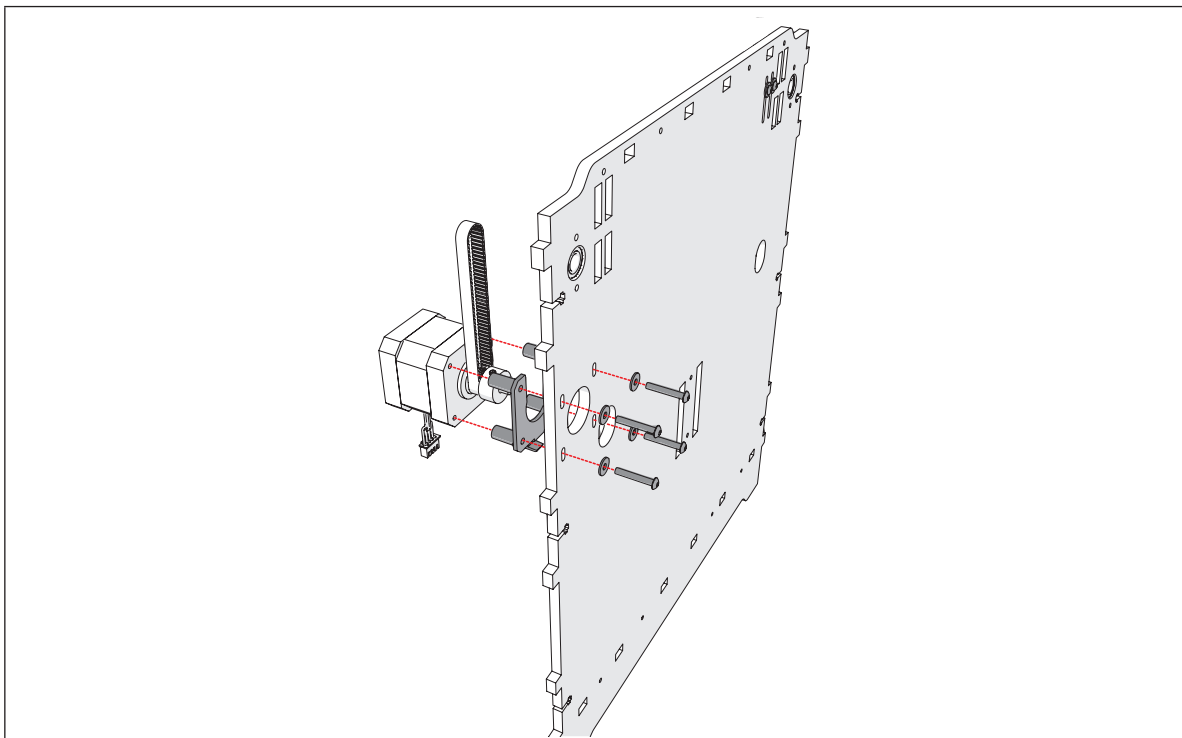

image 11: attaching the X motor on the BACK panel



6.1.4. Step 4: Preparing the BOTTOM panel

The following parts are needed in this step.

Letter	Description	Qty.
A	BOTTOM panel (1007)	1
B	pieces of Velcro (1010)	4

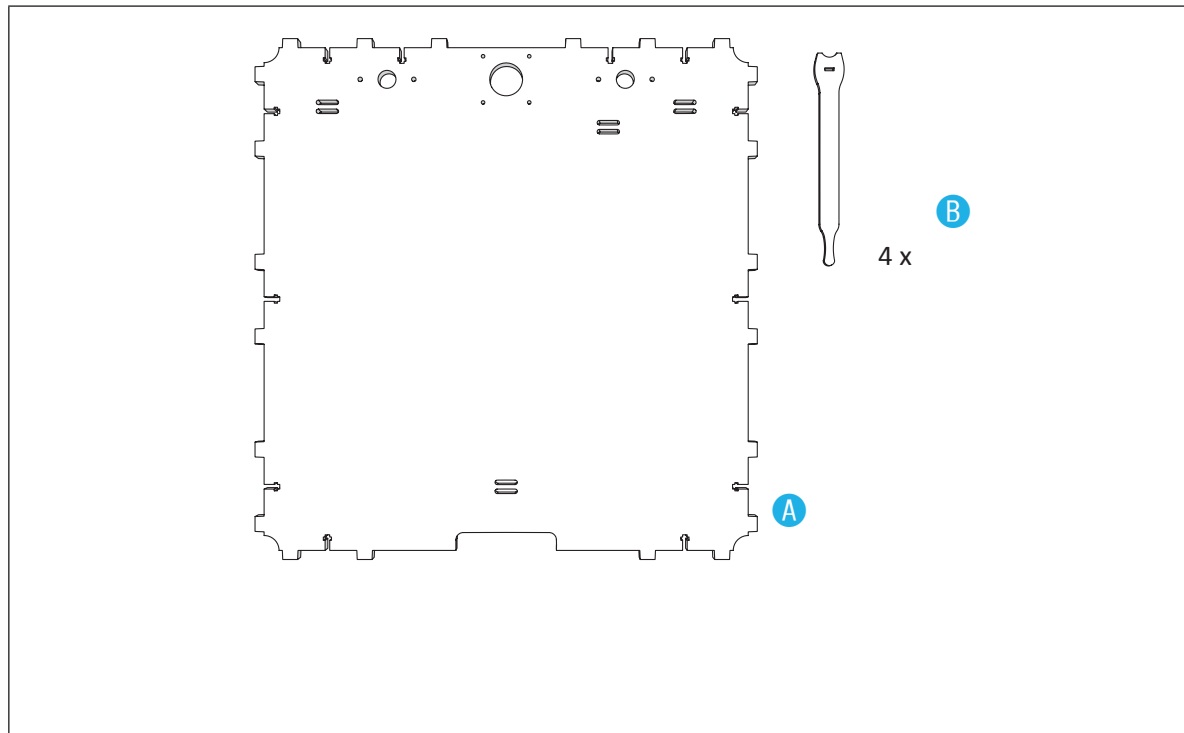

image 12: parts needed for this step

To prepare the BOTTOM panel, perform the following actions:

1. Move 4 pieces black Velcro through the 4*2 slots of the BOTTOM panel.
2. The velcro has to be sticking out at the engraved side of the BOTTOM panel, see image 13.
Make sure the soft side is facing itself after placing.



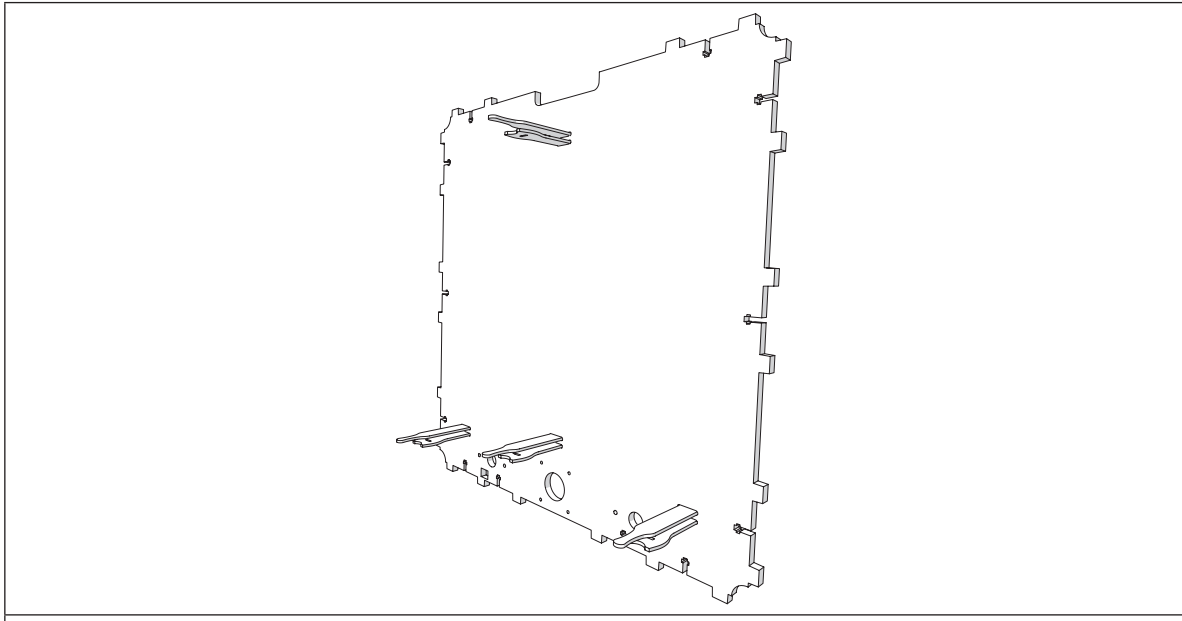

image 13: moving black Velcro through the slots

6.1.5. Step 5: Assembling the 'cube'-shaped frame

The following parts are needed in this step.

Letter	Description	Qty.
	panels (TOP, BOTTOM, FRONT, LEFT, BACK and RIGHT)	6
A	SHORT cable ducts (1132)	2
B	LONG cable ducts (1131)	1
C	blue Scotch tape (1225)	1
D	bolts M3 x 16mm (1204)	37
E	hex nuts 3mm (1209)	37



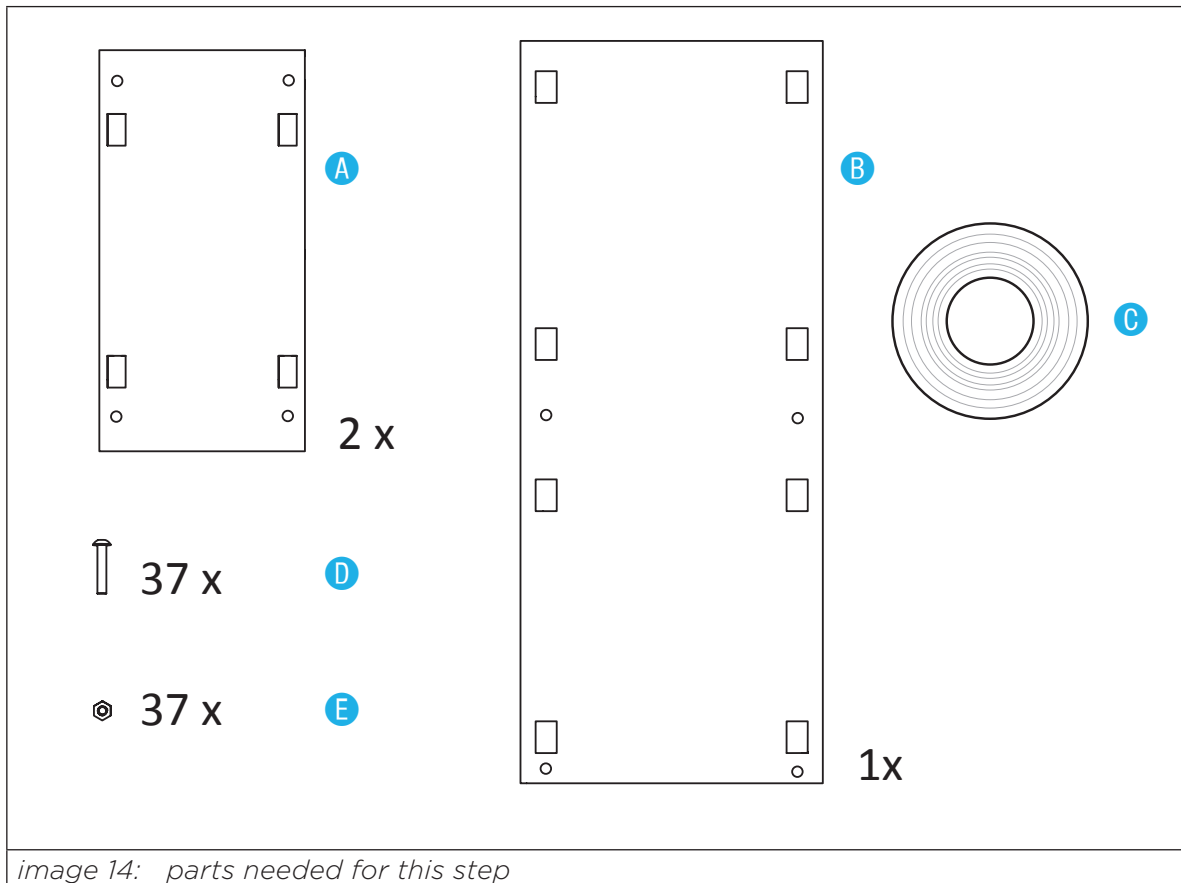

image 14: parts needed for this step



Warning! Be careful not to put any force on the panels because they are weak in this configuration; however they will become very sturdy once you mount a few more panels.

To assemble to 'cube'-shaped frame, perform the following actions:
(for action 1-5 see image 15)

1. Place the BACK panel on the table.
Make sure the markings are facing towards you.
2. Put the TOP panel, with the markings downwards, into the BACK panel.
3. Put the BOTTOM panel into the BACK panel.
4. Put the FRONT panel in the TOP and the BOTTOM panel.
5. Attach the four panels.

Use thirteen bolts M3 x 16mm and thirteen hex nuts 3mm.

- i** **Notice:** loose fixation is highly recommended. You can tighten later.
- i** **Notice:** if you attach the hex nuts, it can be helpful to use some tape to keep them in position.
- i** **Notice:** make sure no cables get jammed before tightening.



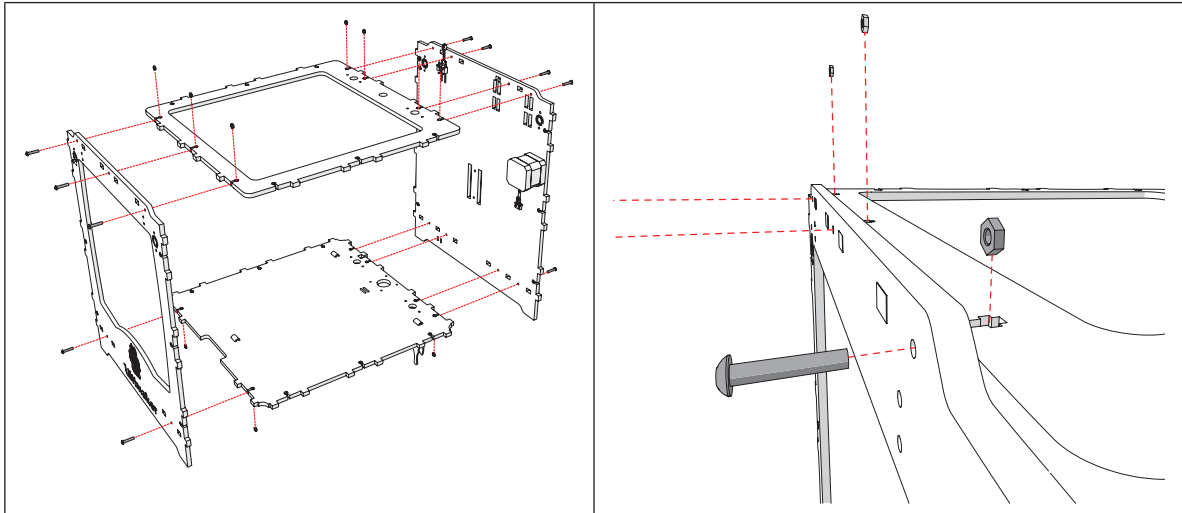

image 15: attaching the BACK, TOP, BOTTOM and FRONT panel

(for action 6-8 see image 16-17)

6. Place a SHORT cable duct on the RIGHT side of the BACK panel.
7. Fold the SHORT cable duct.
8. Tape the folded SHORT cable duct (to keep it folded).

i **Notice:** make sure the blue Scotch tape can be removed easily.

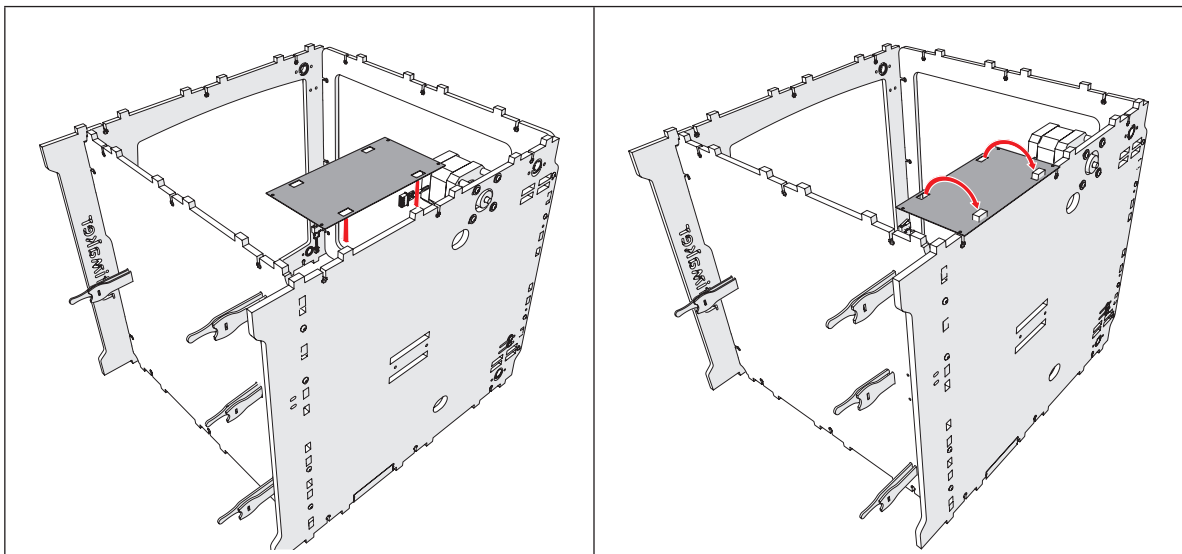

image 16: attaching and folding the SHORT cable duct

9. Place the RIGHT panel.
10. Attach the RIGHT panel.
Use twelve bolts M3 x 16mm and twelve hex nuts 3mm.
11. Remove the blue Scotch tape.



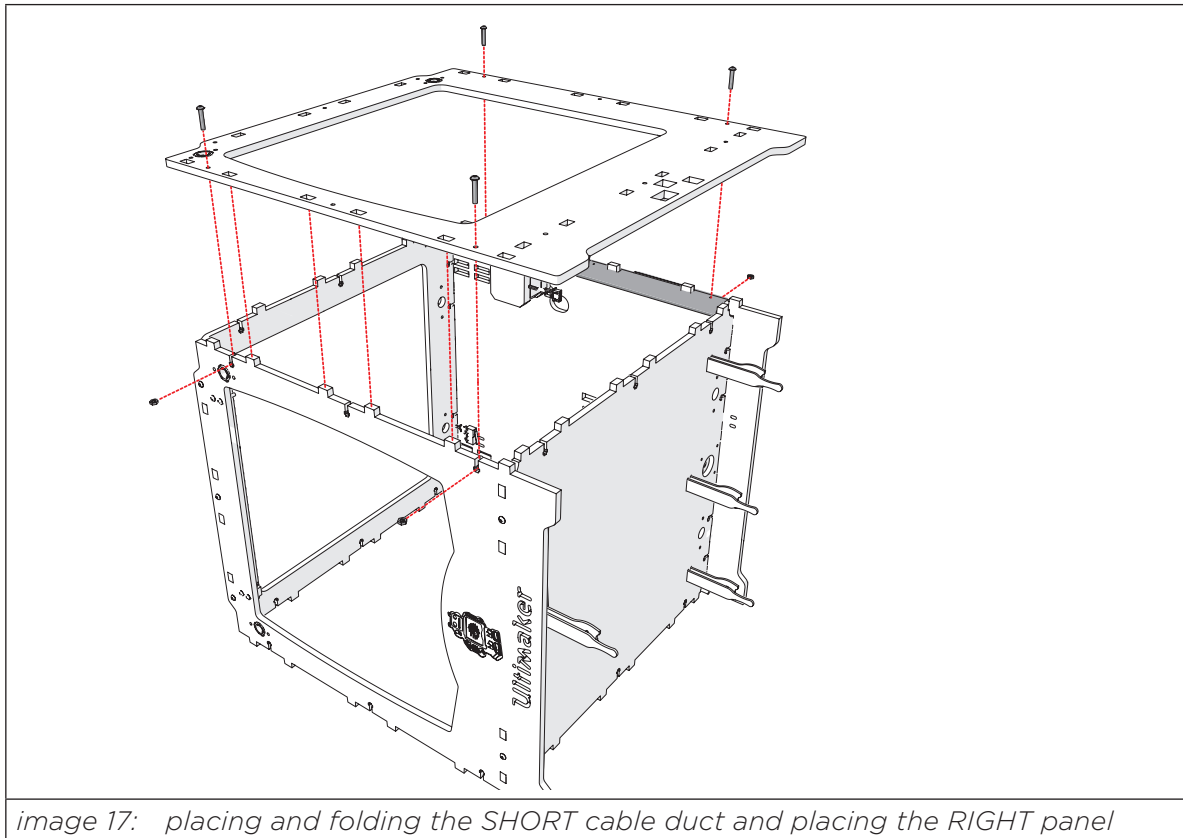

image 17: placing and folding the SHORT cable duct and placing the RIGHT panel

(for action 15-20 see image 18)

12. Turn the Ultimaker Original+ on it's RIGHT side.
13. Place the second SHORT cable duct on the LEFT side of the BACK panel, fold it and tape it.
14. Place a LONG cable duct on the Left side of the FRONT panel and check if it is alligned correctly
15. Fold the LONG cable duct.
16. Tape the folded LONG cable duct (to keep it folded).
- i** **Notice:** make sure the blue Scotch tape can be removed easily.
17. Place the LEFT panel.
18. Attach the LEFT panel.
Use twelve bolts M3 x 16mm and twelve hex nuts 3mm.
19. Remove the blue Scotch tape.



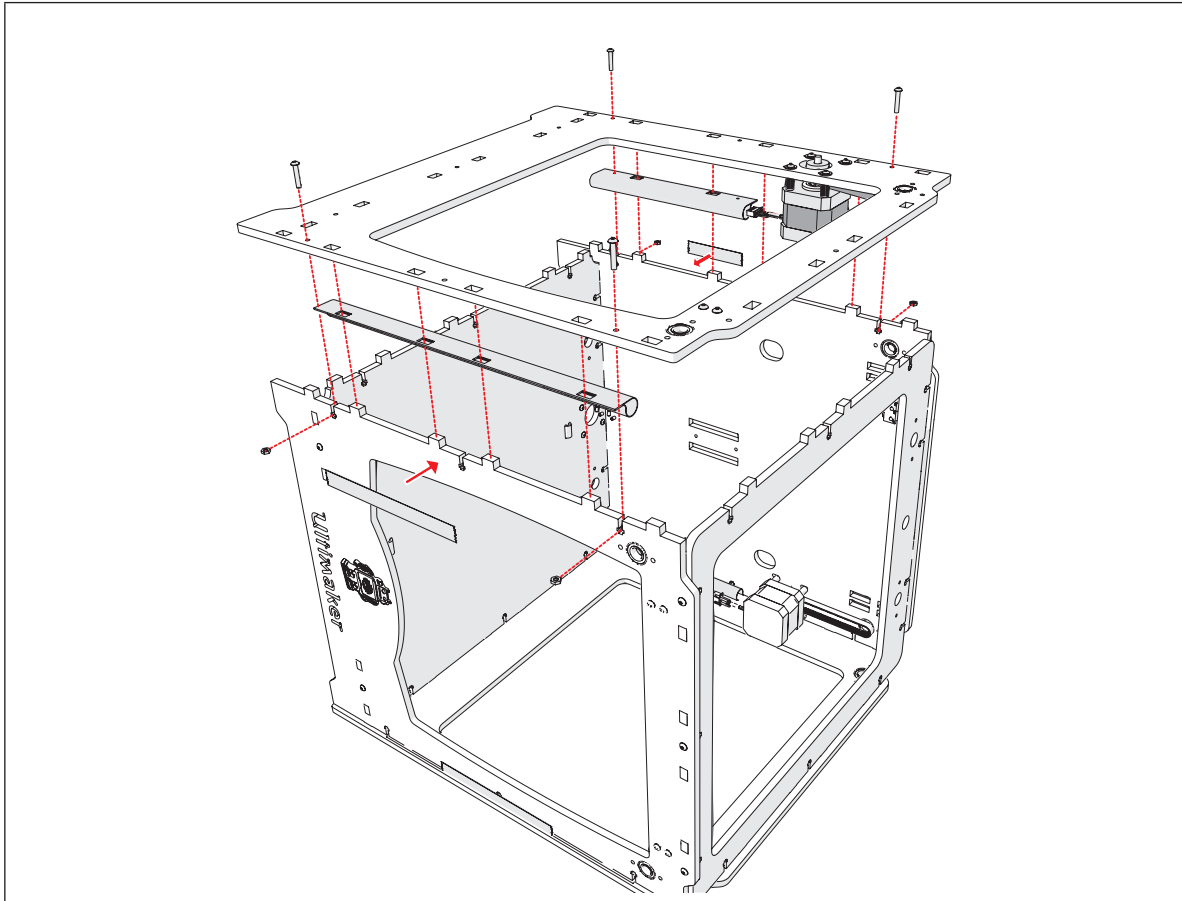

image 18: positioning the other SHORT and LONG cable ducts and attaching the LEFT panel

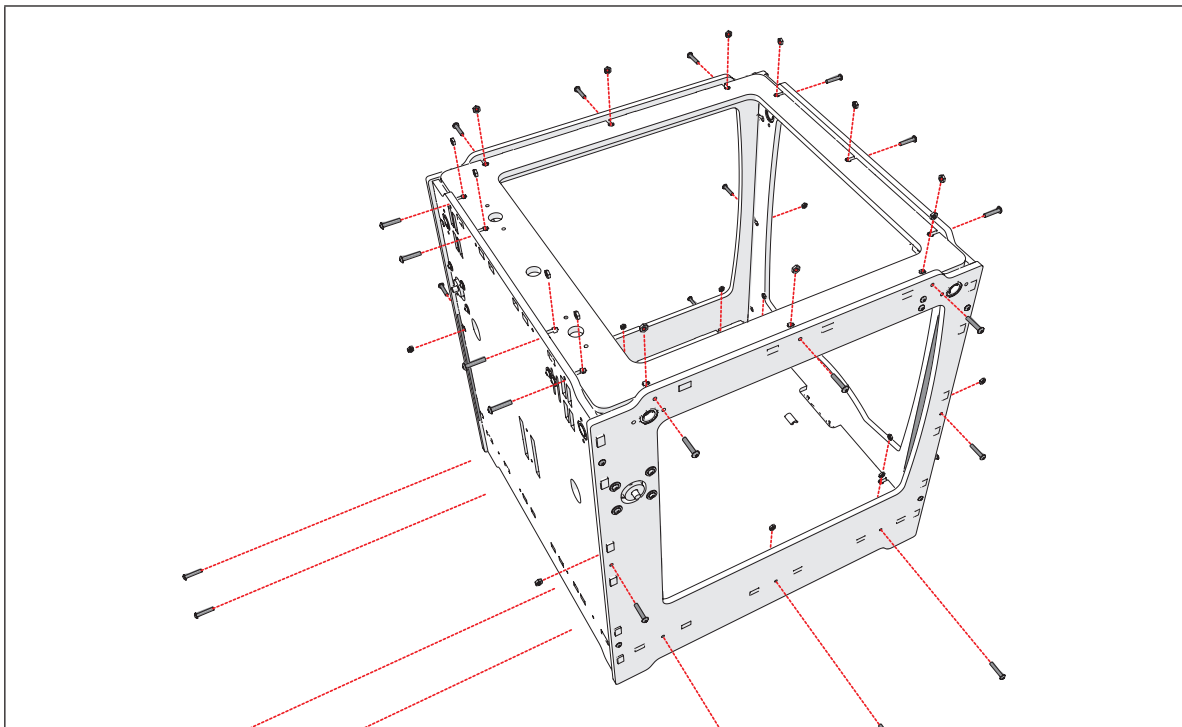
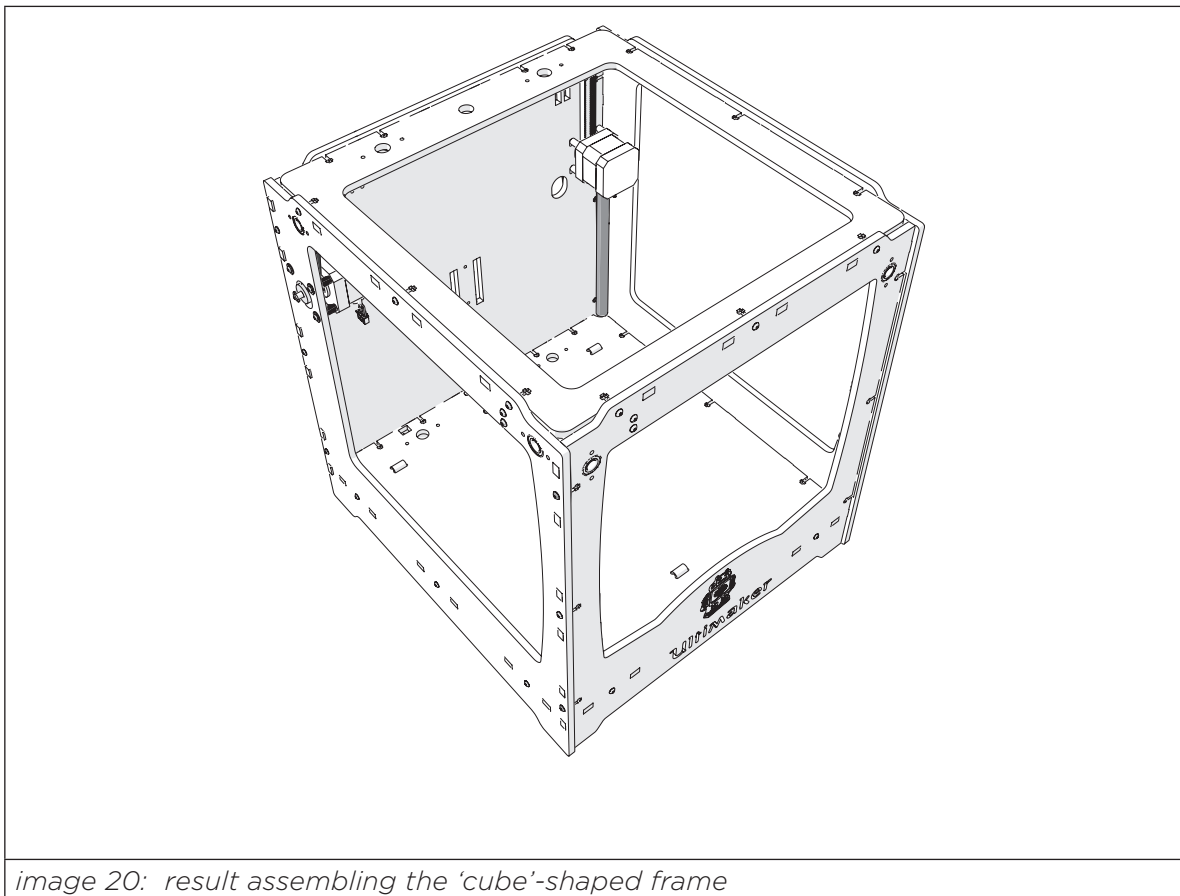

image 19: complete the frame by checking if all the bolts are tightened



20. Move the wires of the limit switches through the cable ducts.
 - i** Guide the wires of the Z-limit switch behind the Y-Motor, you might need to unbolt it a little to make some room
21. Move the wires of the X- and Y motor through the cable ducts.
22. Complete the frame, see image 19.
 - Use twelve bolts M3 x 16mm.
 - i** You can use the Velcro to temporarily keep the cables in place.

Well done, the frame should look like this (see image 20).



6.1.6. Step 6: attaching various parts

The following parts are needed in this step.

Letter	Description.	Qty.
A	wooden part 11A (rounded square) (1009)	1
B	wooden part 3A (1044)	2
C	bolts M3 x 16mm (1204)	6
D	hex nuts 3mm (1209)	4
E	lock nuts M3 (1214)	2

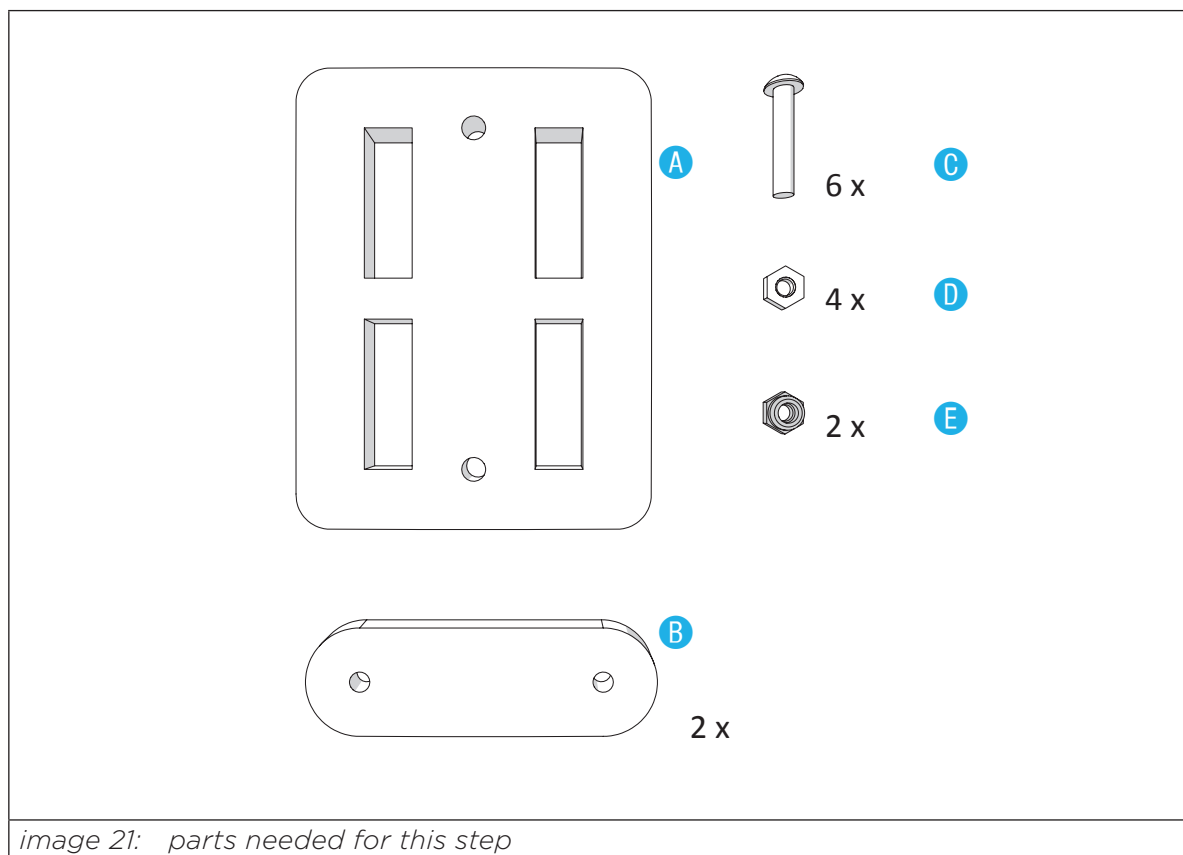

To attach the various parts, perform the following actions:

1. Attach wooden part 11A, see image 22.
i **Make sure the lock nuts M3 are attached on the outside.**
Use two lock nuts M3 and two bolts M3 x 16mm.
2. Attach two wooden parts 3A to the bottom of the machine.
Use two bolts M3 x 16mm and two nuts M3 for each wooden part 3A.
See image 23
i **Notice:** wooden part 3A is 6mm thick, NOT 4mm.



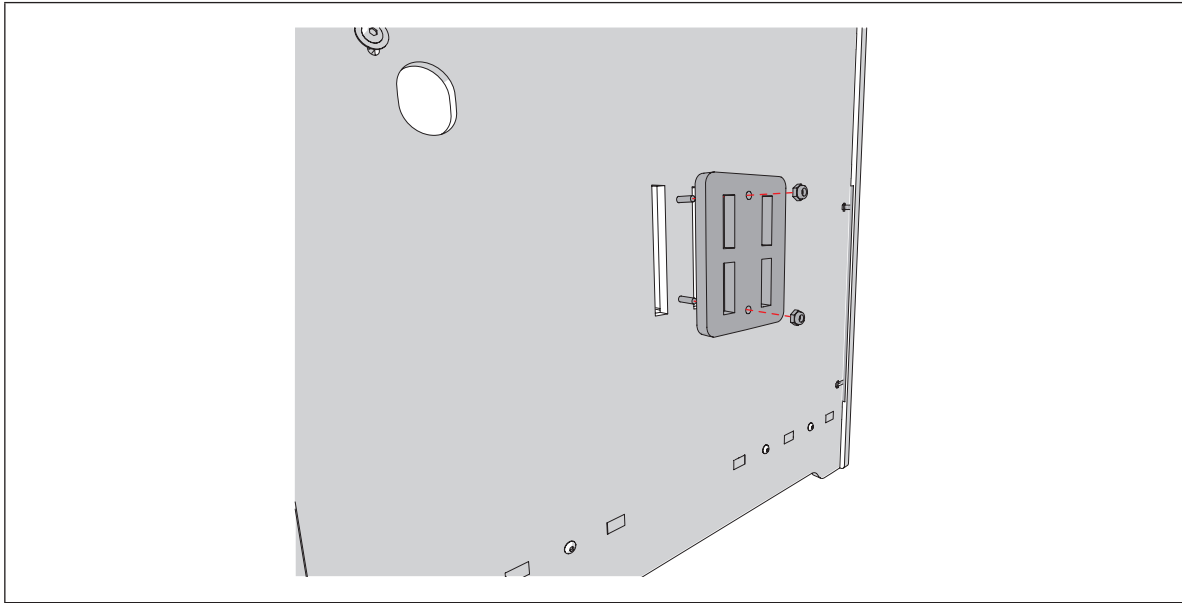

image 22: attaching part 11A

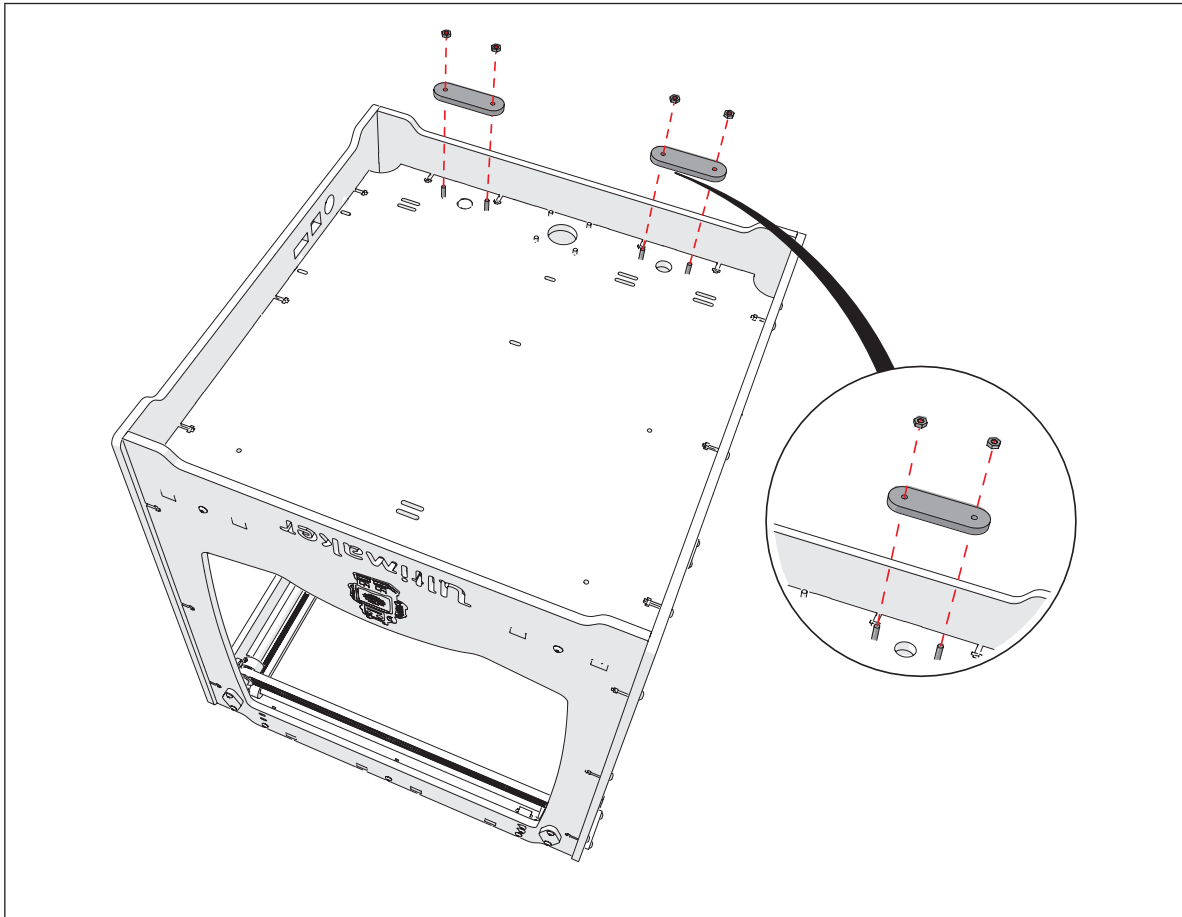

image 23: attaching wooden parts 3A

Great work! The frame is now ready! On to the next section.



6.2

ASSEMBLING THE X/Y AXES

WHAT YOU'LL NEED TO
ASSEMBLE THE X/Y AXES.

Time:

about 60 to 90 minutes

Tools:

hex keys (2mm)

hex keys (1,5mm)

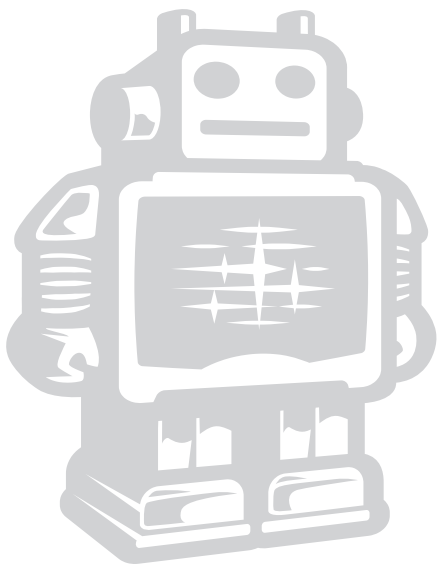

6.2.1. Step 1: Assembling the FRONT, BACK, RIGHT, LEFT slider blocks

The following parts are needed in this step.

Letter	Description.		Qty.
A	Sliderblock parts	sliderblock parts 6mm 12 x sliderblock part 4mm 8 x	20
B	Copper Sintered Bushing 30mm (1056)		4

























	FRONT slider block	LEFT slider block	RIGHT slider block	BACK slider block
A	 a  b  c  d  e	 a  b  c  d  e	 a  b  c  d  e	 a  b  c  d  e
B	 f	 f	 f	 f

image 24: parts needed for this step

To assemble the FRONT, RIGHT, LEFT, BACK slider blocks, perform the following actions:

1. Push the bushing through the wooden parts, see image 25.
Make sure the bushing sticks out both sides of the FRONT slider block (approx. 1 mm)

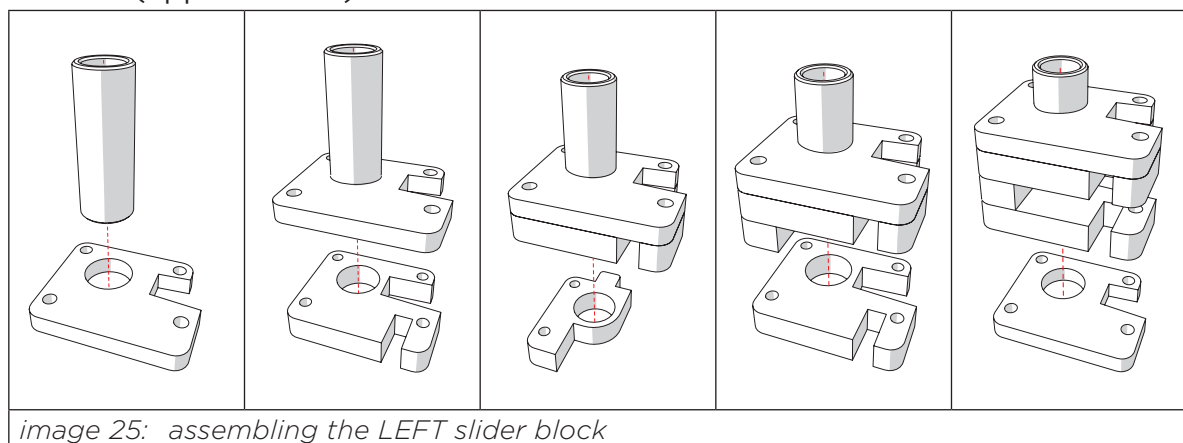
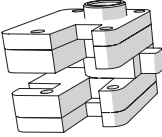

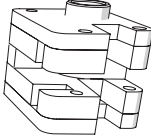

image 25: assembling the LEFT slider block



2. Do the same for the RIGHT, LEFT, and BACK slider blocks. Make sure the order of the wooden parts are correct.

FRONT slider block	
LEFT slider block	
RIGHT slider block	
BACK slider block	
<i>image 26: Result assembling FRONT, LEFT, RIGHT and BACK slider blocks</i>	

6.2.2. Step 2: Attaching the claws

The following parts are needed in this step.

Letter	Description	Qty.
A	FRONT, LEFT, RIGHT, BACK slider blocks	4
B	bolts M3 x 10mm (1202)	8
C	4mm wooden parts marked C (rectangular)	4
D	hex nuts 3mm (1209)	24
E	bolts M3 x 30mm (1208)	12
F	6mm wooden parts marked C	4



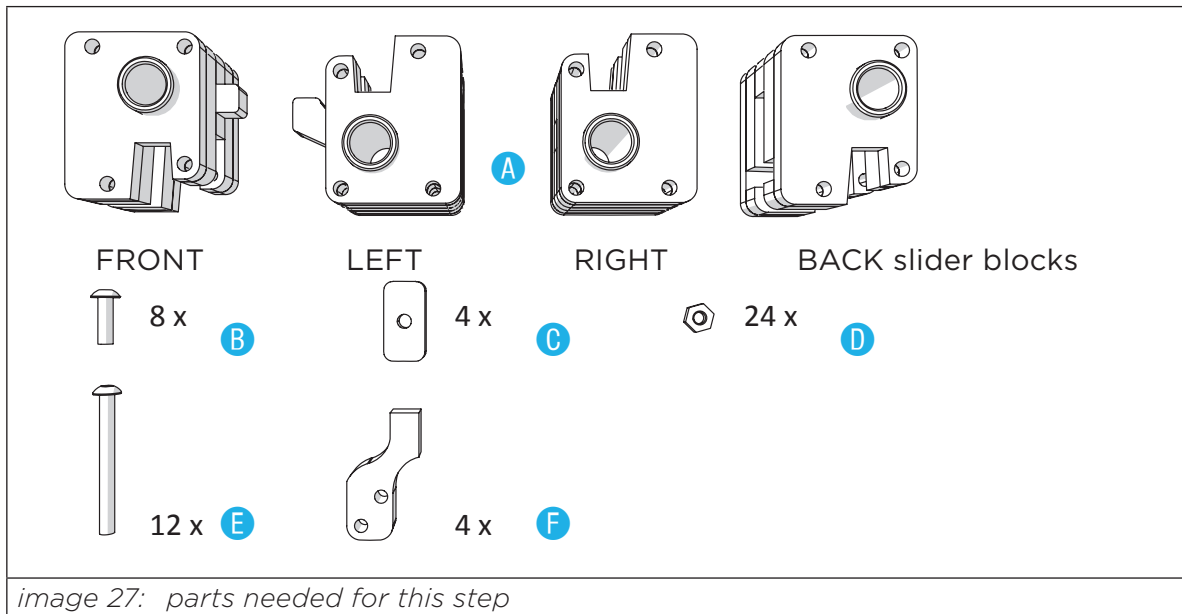

To attach the claws, perform the following actions:

1. Attach the bolt to the 6mm wooden part marked Front, Back, Left, Right C, see image 28.

Use one bolt M3 x 10mm and two hex nuts 3mm.

i **Notice:** the last hex nut will barely fit in. This is normal.

2. Place the wooden part marked C in the FRONT slider block.
3. Place three bolts M3 x 30mm, see image 29.
4. Attach the nuts, see image 29.

i **Notice:** do not tighten the nuts too much. The claw must be able to rotate.

5. Repeat action 1-5 three times to attach all wooden parts marked C on all slider blocks.

6. Assemble the wooden parts, marked C, see image 30.
Use one bolt M3 x 10mm and one nut.

i **Notice:** This assembled 4mm wooden parts marked C will be used later on in the build process.

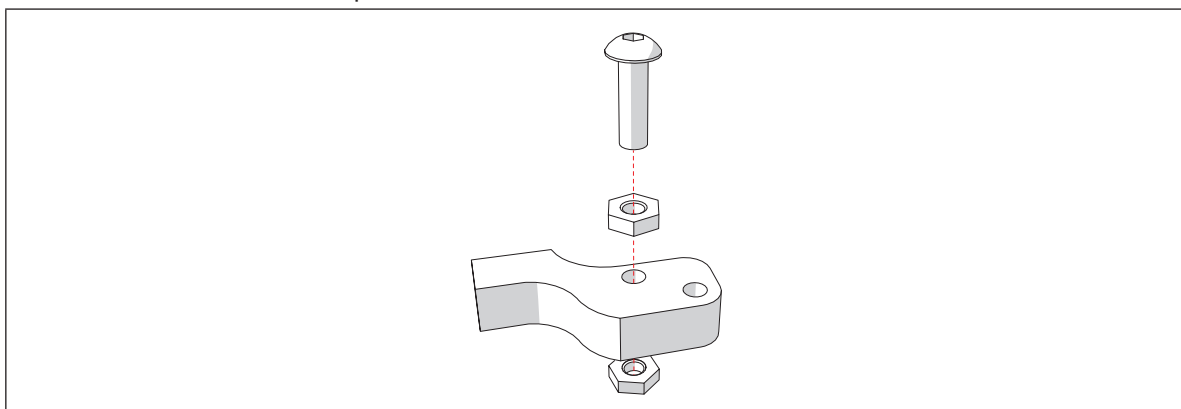

image 28: attaching the bolt to the 6mm wooden part marked Front, Back, Left, Right

C



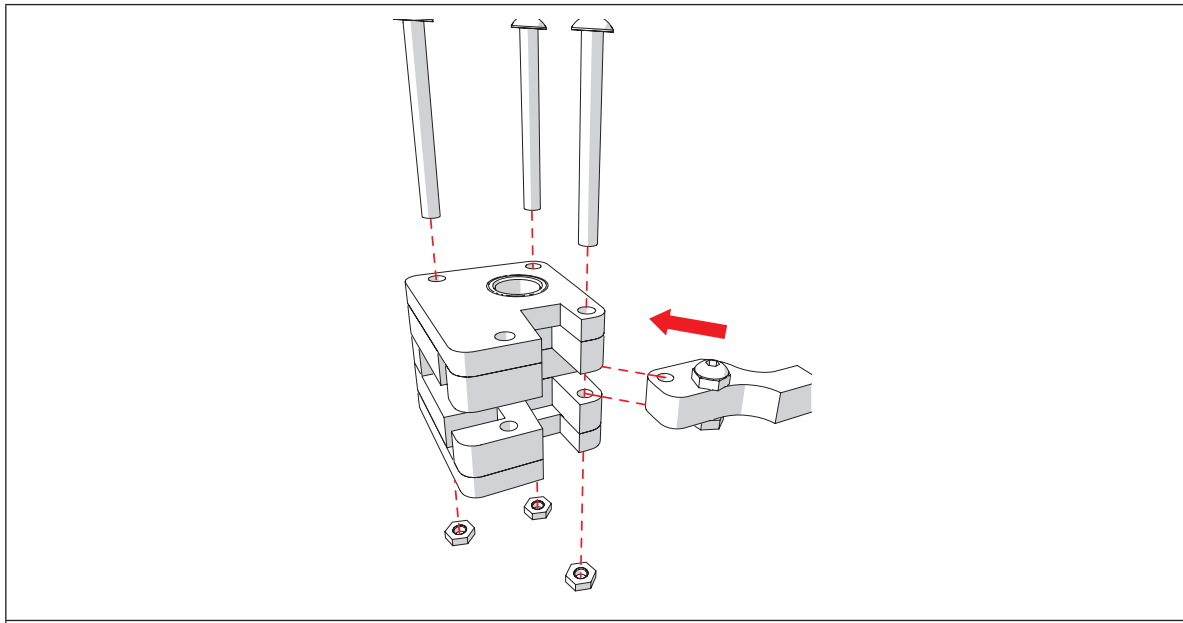

image 29: placing the wooden part marked C in the FRONT slider block

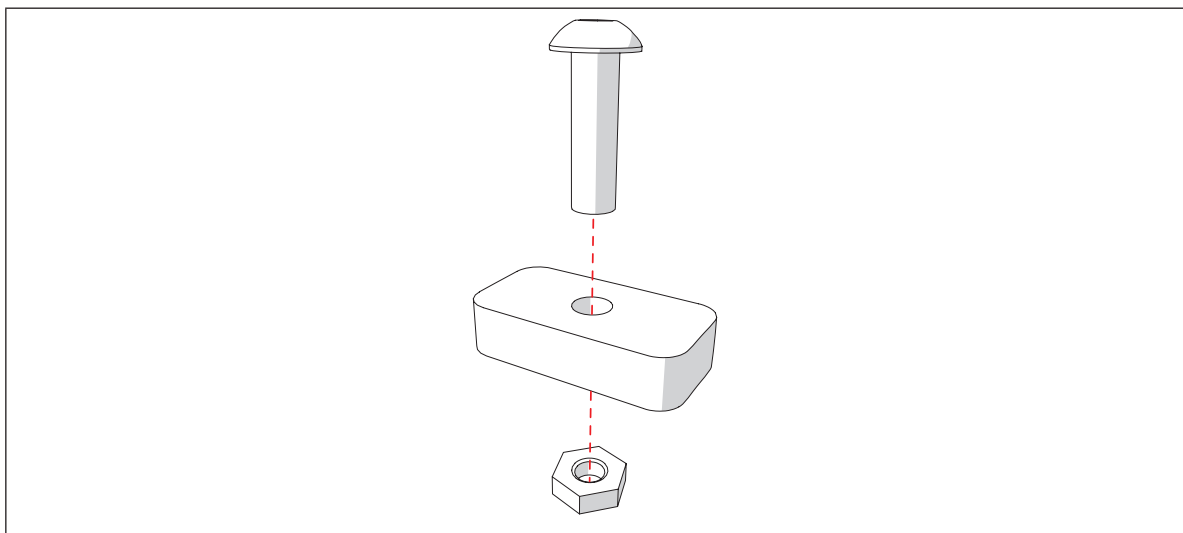

image 30: assembling wooden parts, marked C

6.2.3. Step 3: Mounting the caps

The following parts are needed in this step.

Letter	Description	Qty.
A	wooden caps outside (WITHOUT hole) (1029)	8
B	wooden caps inside (WITH hole) (1045)	6
C	hex nuts 3mm (1209)	16
D	bolts M3 x 16mm (1204)	16



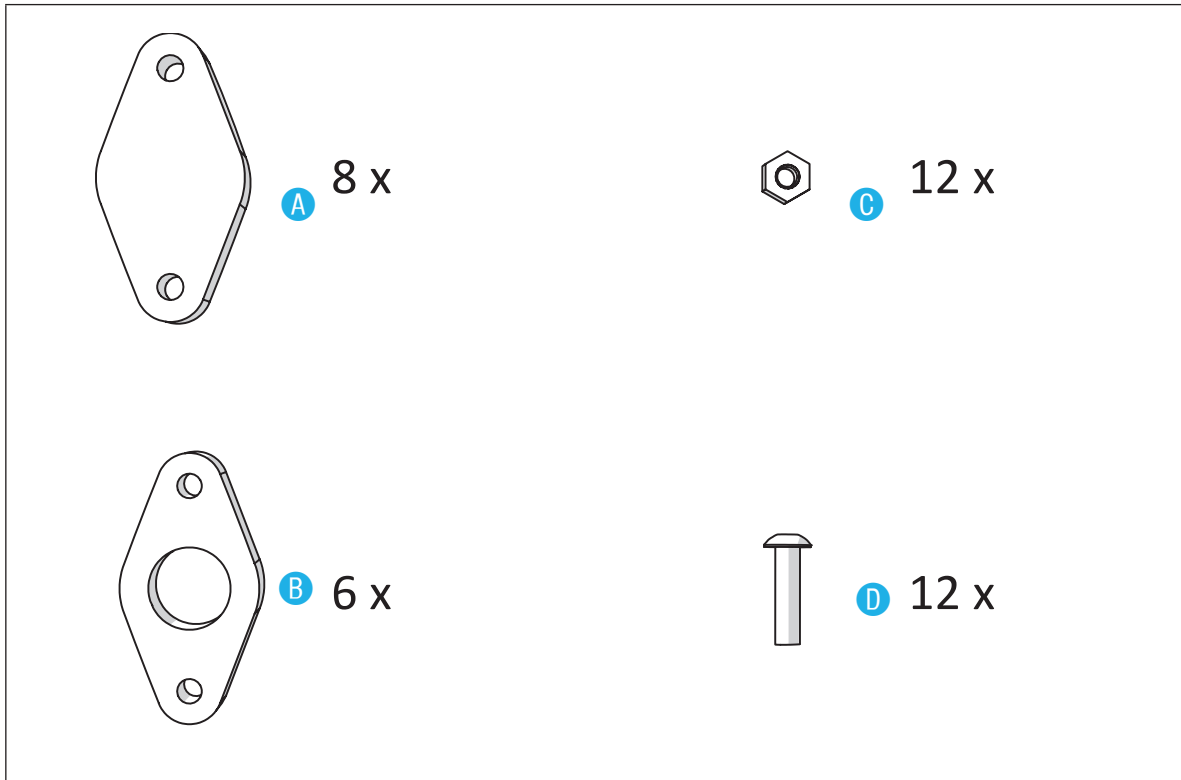

image 31: parts needed for this step

The wooden caps have to be attached in four corners of the Ultimaker Original+. To help you performing the actions, the following overview is provided, see image 32. In the places where the motor belts pass over the bearings there should not be any part **B**, Some of the Caps only need to be attached with one bolt at this time to help inserting the axles at a later stage.

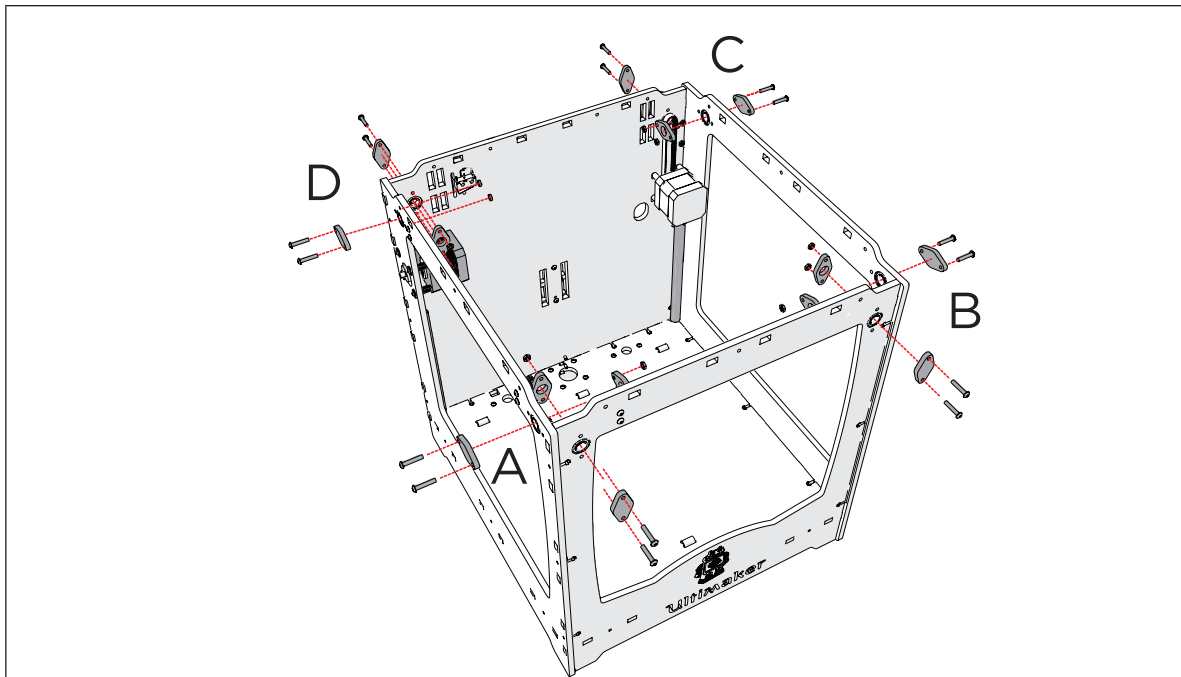

image 32: overview different corners



To attach the wooden caps, perform the following actions:

1. Attach the wooden caps in corner A, see image 33.
The wooden caps WITH hole on the inside, the wooden end caps WITHOUT hole on the outside.

i **Notice:** Use two bolts M3 x 16mm and two hex nuts 3mm at both panels.

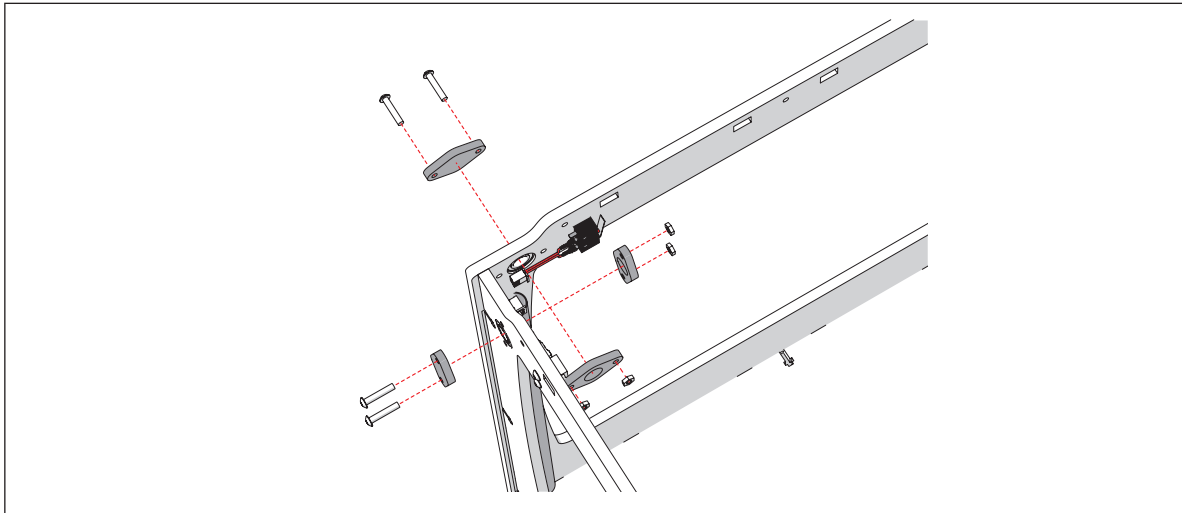

image 33: attaching the wooden caps in corner A

2. Attach the wooden caps in corner B, see image 34.
The wooden caps WITH hole on the inside, the wooden end caps WITHOUT hole on the outside.

i **Notice:** Use ONE bolt M3 x 16mm and ONE hex nut 3mm at the RIGHT panel.

i Use two bolts M3 x 16mm and two hex nuts 3mm at the FRONT panel.

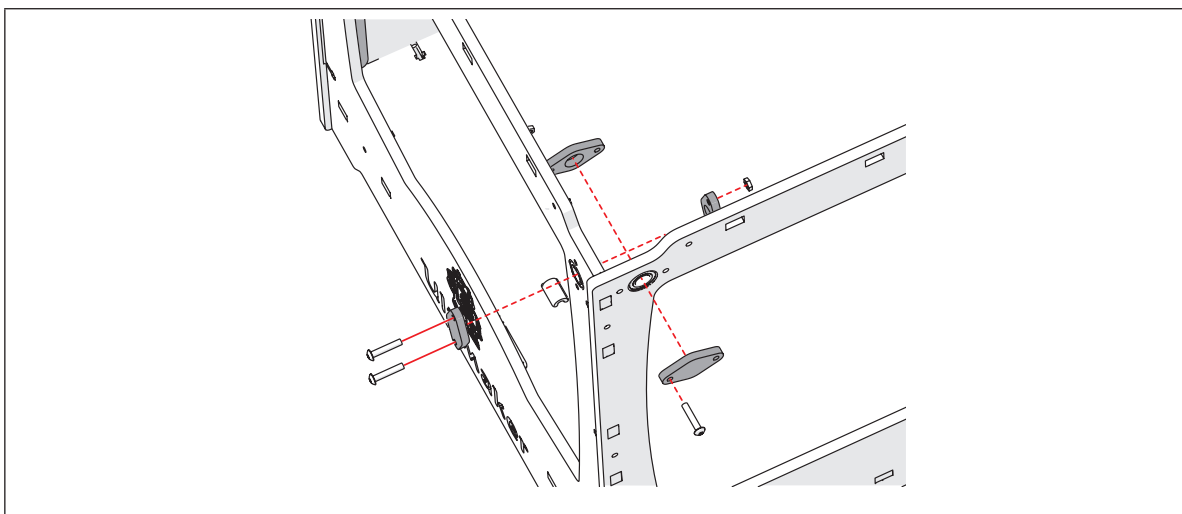

image 34: attaching the wooden caps in corner B



3. Attach the wooden caps in corner C, see image 35.
The wooden caps WITH hole on the inside, the wooden end caps WITHOUT hole on the outside.

Use ONE wooden end cap WITHOUT hole at the BACK panel.

i **Notice:** Use ONE bolt M3 x 16mm and ONE hex nut 3mm at the RIGHT panel.

i **Notice:** Use ONE bolt M3 x 16mm and ONE hex nut 3mm at the BACK panel,

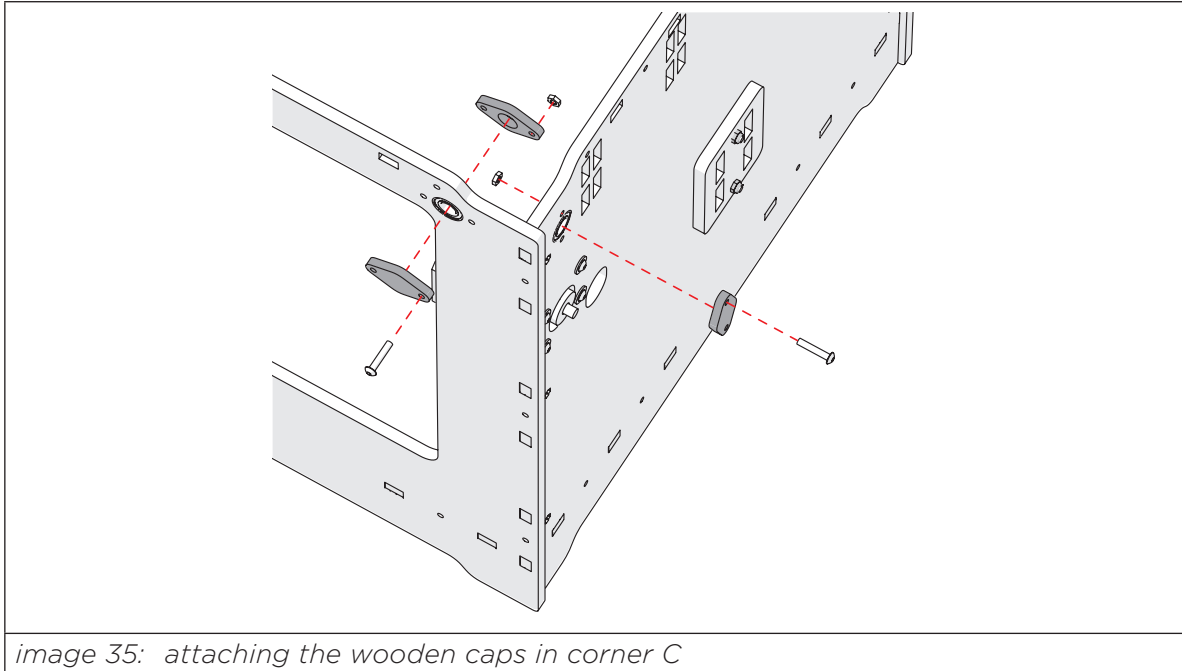

image 35: attaching the wooden caps in corner C

4. Attach the wooden caps in corner D, see image 36.
The wooden caps WITH hole on the inside, the wooden end caps WITHOUT hole on the outside.

Use ONE a wooden end cap WITHOUT hole at the LEFT panel

i **Notice:** Use ONE bolt M3 x 16mm and ONE hex nut 3mm at the BACK panel,

i **Notice:** Use two bolt M3 x 16mm and two hex nuts 3mm at the LEFT panel.



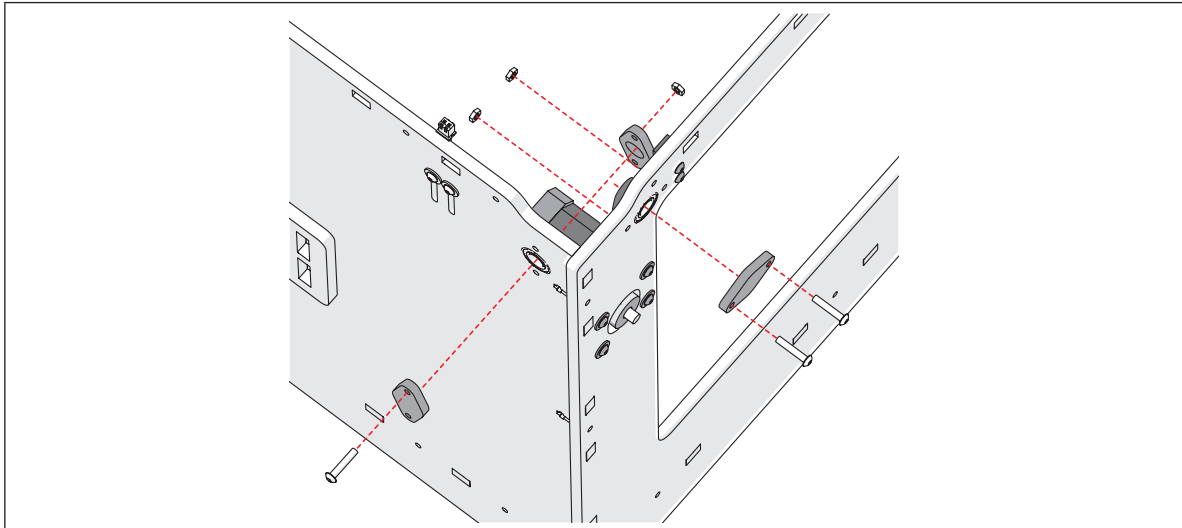

image 36: attaching the wooden caps in corner D

6.2.4. Step 4: Mounting the axes

The following parts are needed in this step.

Letter	Description	Qty.
	FRONT, LEFT, RIGHT, BACK slider blocks (Step 1 [6.2.1])	4
A	Long timing belts (1086)	4
B	axes SHORT (1012)	2
C	axes LONG (1011)	2
D	timing pulleys (1086)	10
E	Stainless Steel Setscrew (1211)	10
F	bolts M3 x 16mm (1204)	4
G	hex nuts 3mm (1209)	4

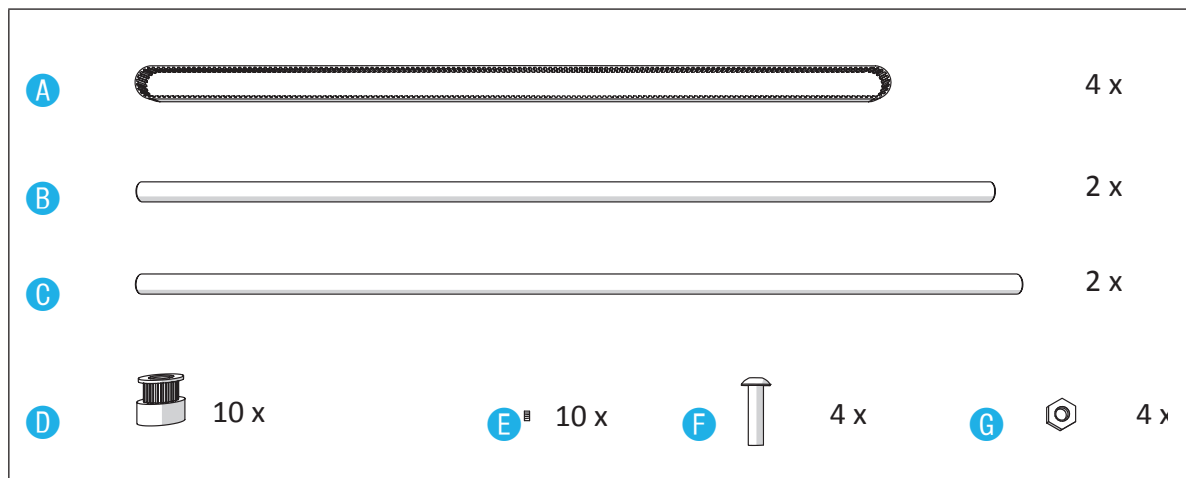

image 37: parts needed for this step



To help you performing the actions, the following overview is provided, see image 38.

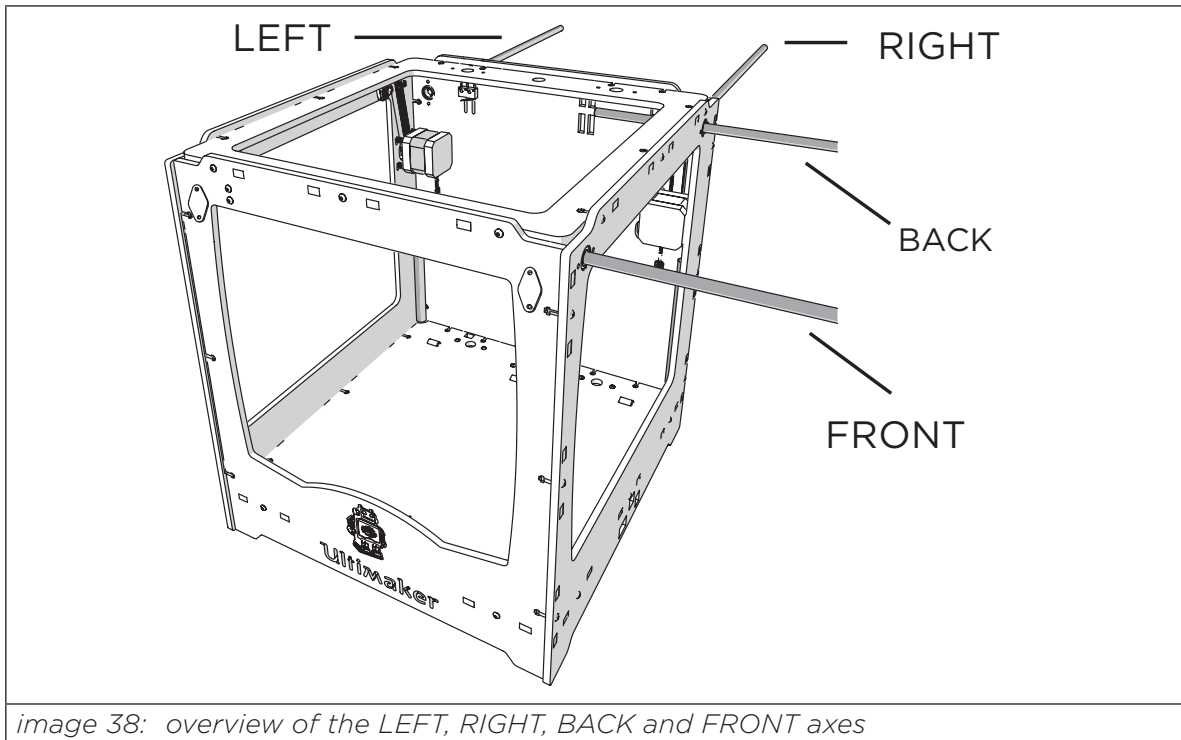

image 38: overview of the LEFT, RIGHT, BACK and FRONT axes

i Notice: Prepare all the pulleys by replacing the setscrew that is inside the pulleys by the Stainless Steel setscrew that is separately supplied.

i Notice: Guide the wires of the endstop switches in such a way that they don't get stuck on the pulleys

To attach axis FRONT (SHORT) perform the following actions:

1. Get axis SHORT
2. Rotate the wooden end cap WITHOUT hole (RIGHT panel, FRONT), see image 39.

3. Put the pulleys on the timing belts.

Use ONE timing pulleys for each timing belt.

i **NOTICE:** the thinnest side of the timing pulley is facing to the outside.

4. Move the axis SHORT from the RIGHT panel to the LEFT panel, see image 41.

Place the following parts, in order, on the axis SHORT:

- timing belt with ONE timing pulley.
- FRONT slider block.

i **NOTICE:** the clamp of the FRONT slider block is facing downwards along the FRONT panel, see image 40.

- timing belt with ONE timing pulley.

5. Rotate the wooden end cap WITHOUT hole (RIGHT panel, FRONT) back to its normal position.

6. Attach the wooden end gap WITHOUT hole with a bolt M3 x 16mm and a hex nut 3mm.



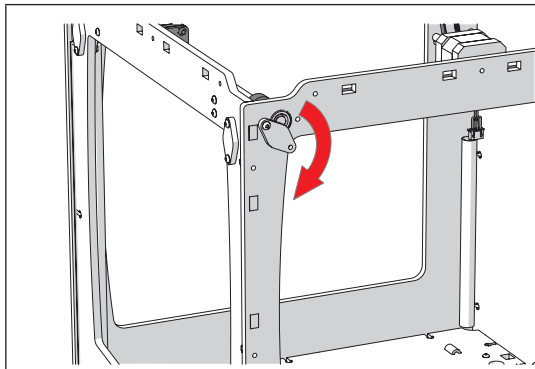

image 39: rotating the wooden end cap WITHOUT hole

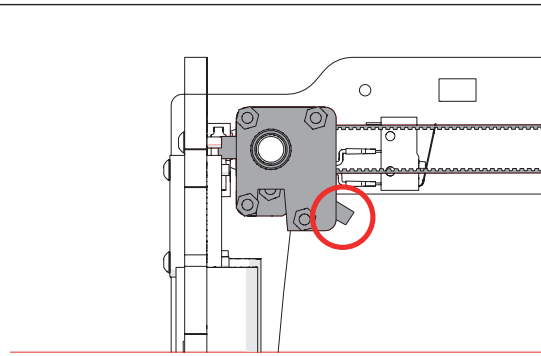

image 40: Side view FRONT slider block

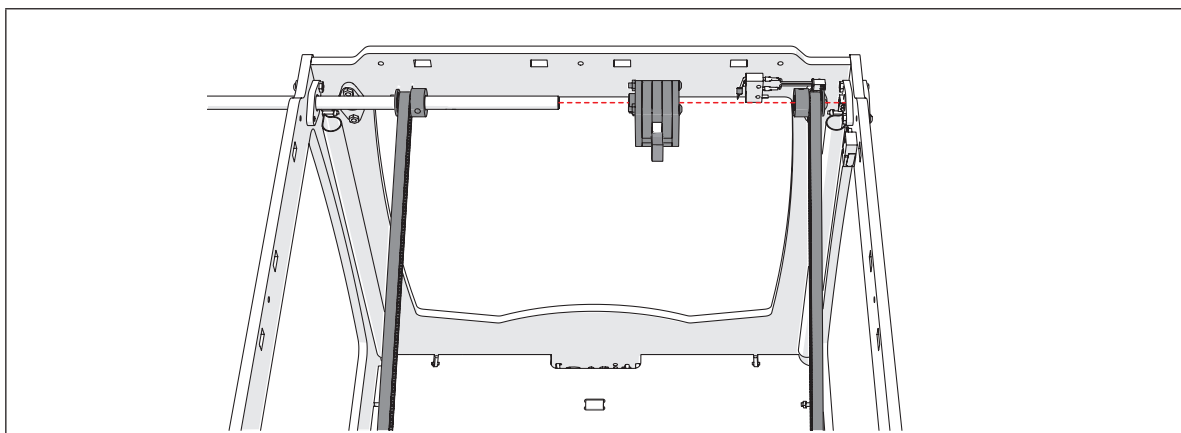

image 41: attaching the FRONT axis

To attach the axis BACK (SHORT) perform the following actions:

1. Get a axis SHORT.
2. Rotate the wooden end cap WITHOUT hole (RIGHT panel, BACK).
3. Put the pulleys on the timing belts.
Use ONE timing pulley for each timing belt which is connected to axis SHORT (FRONT panel).
Use ONE timing pulley for the timing belt which is connected to the motor.
- i** **NOTICE:** the thinnest side of the timing pulley is facing to the outside.
4. Move the axis SHORT. from the RIGHT panel to the LEFT panel, see image 42.
Place the following parts, in order, on the axis SHORT:
 - timing belt which is connected to axis SHORT (FRONT panel) with ONE timing pulley.
 - BACK slider block.
 - timing belt which is connected to axis SHORT (FRONT panel) with ONE timing pulley.
 - timing belt which is connected to the motor with ONE timing pulley.



- i** **NOTICE:** the clamp of the BACK slider block is facing downwards along the BACK panel
 - timing belt which is connected to axis SHORT (FRONT panel) with ONE timing pulley.
- 5. Rotate the wooden end cap WITHOUT hole (RIGHT panel, BACK) back to its normal position.
- 6. Attach the wooden end cap WITHOUT hole with ONE bolt M3 x 16mm and ONE hex nut 3mm.

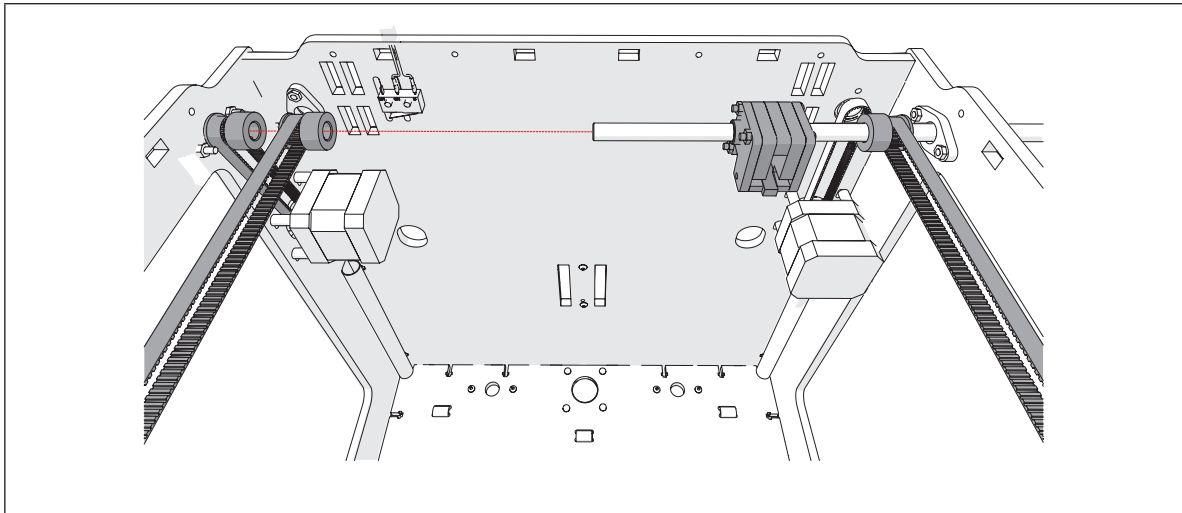

image 42: attaching the BACK axis

To attach the Axis Left (LONG) perform the following actions:

1. Get an Axis (LONG).
2. Rotate the wooden end cap WITHOUT hole (BACK panel, LEFT).
3. Put the pulleys on the timing belts.
 - Use ONE timing pulley for each timing belt.
- i** **NOTICE:** the thinnest side of the timing pulley is facing to the outside.
4. Move the axis LONG from the BACK panel to the FRONT panel, see image 43.
 - Place the following parts, in order, on the axis:
 - timing belt with ONE timing pulley.
 - LEFT slider block.
- i** **NOTICE:** the clamp of the LEFT slider block is facing upwards along the LEFT panel.
 - timing belt with ONE timing pulley.
5. Put the timing belt in the FRONT slider block, see image 44.
6. Put the timing belt in the BACK slider block, see image 45.
7. Rotate the wooden end cap WITHOUT hole (BACK panel, LEFT) back to its normal position.
8. Attach the wooden end cap WITHOUT hole with a bolt M3 x 16mm and a hex nut 3mm.



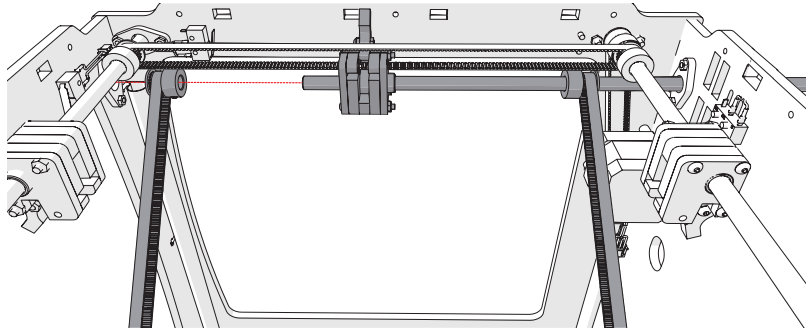

image 43: attaching the LEFT axis.

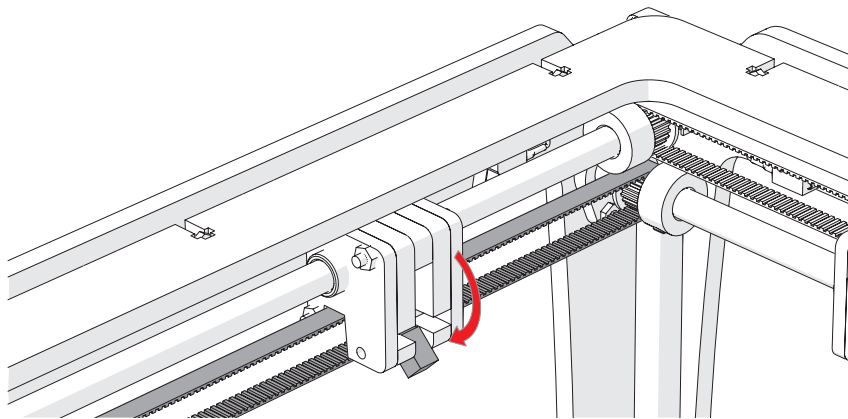

image 44: attaching the FRONT slider block on the timing belt

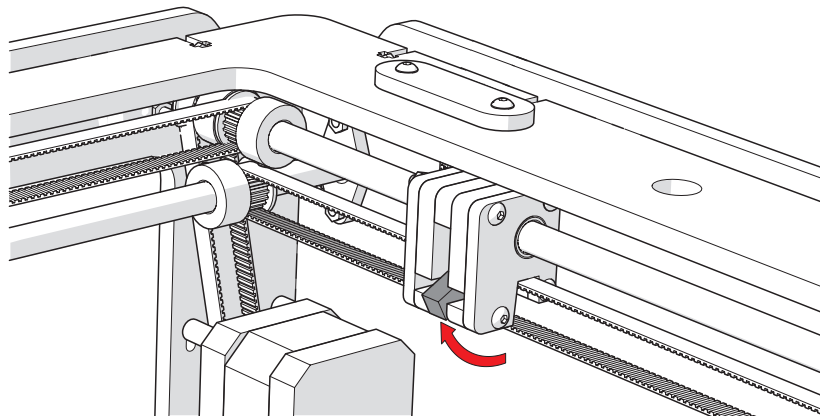

image 45: attaching the BACK slider block on the timing belt

To attach axis RIGHT (LONG) perform the following actions:

1. Get a axis LONG.
2. Rotate the wooden end cap WITHOUT hole (BACK panel, RIGHT).
3. Put the pulleys on the timing belts.

Use ONE timing pulley for the timing belt which is connected to the motor.

Use ONE timing pulley for each timing belt which is connected to axis



LONG (LEFT panel).

i **NOTICE:** the thinnest side of the timing pulley is facing to the outside.

4. Move the axis LONG from the BACK panel to the FRONT panel, see image 46.

Place the following parts, in order, on the axis LONG:

- timing belt which is connected to the motor with timing pulley.
- timing belt which is connected to axis LONG with ONE timing pulley.
- RIGHT slider block.

i **NOTICE:** the clamp of the RIGHT slider block is facing upwards along the RIGHT panel.

- timing belt which is connected to axis LONG (LEFT panel) with ONE timing pulley.
5. Rotate the wooden end cap WITHOUT hole (BACK panel, LEFT) back to its normal position.
 6. Attach the wooden end ap WITHOUT hole with a bolt M3 x 16mm and a hex nut 3mm.

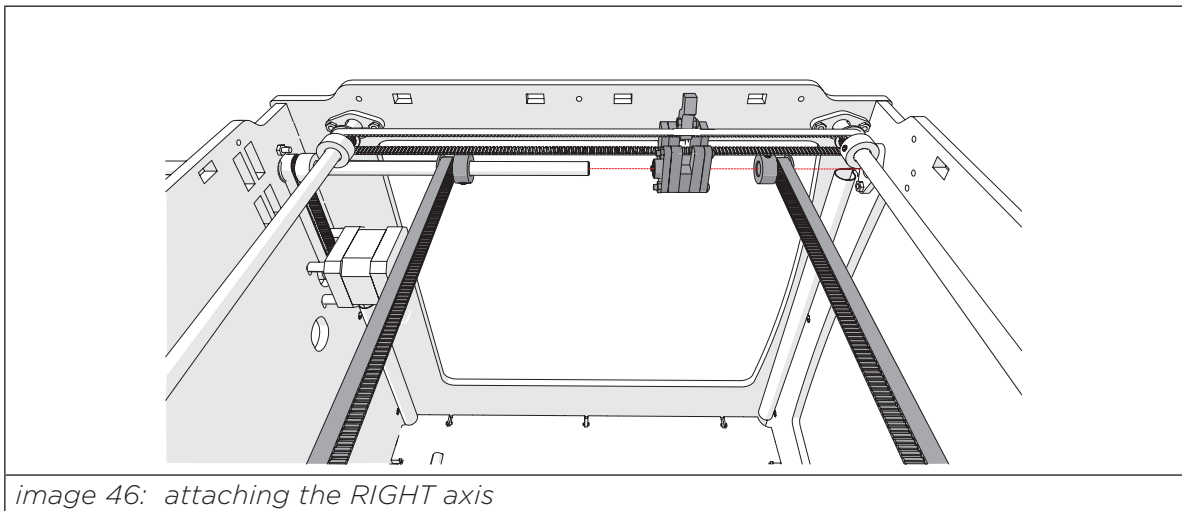

image 46: attaching the RIGHT axis

i Notice: Check if all the axis are able to turn freely. If not try to add some washers between the endcaps and the frame on the outside.



6.3

ASSEMBLING THE EXTRUSION HEAD

WHAT YOU'LL NEED
TO ASSEMBLE
THE EXTRUSION HEAD.

Time:

about 60 to 90 minutes

Tools:

hex keys (2mm)

hex keys (1,5mm)

pliers

small screwdriver (1,5mm)

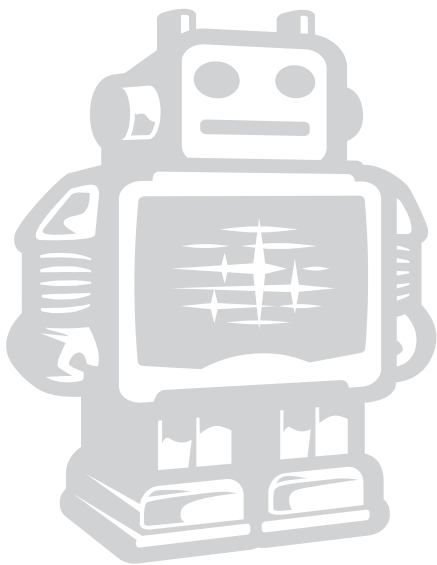

6.3.1. Step 1: Assemble the extrusion head housing

The following parts are needed in this step.

Letter	Description	Qty.	Letter	Description	Qty.
A	spiral wrapping (1097)	1	L	cartridge heater (1513)	1
B	long studding bolts (1680)	4	M	PT100 (1185)	1
C	brass pipe (1053)	1	N	wooden part FRONT, BACK, LEFT, RIGHT	4
D	teflon coupler (1055)	1	O	wooden part 8B (1061)	1
E	peek (1067)	1	P	aluminium plate (1048)	1
F	aluminium heater block (1049)	1	Q	wooden part TOP (1059)	1
G	nozzle (1054)	1	R	blue horse shoe (1071)	1
H	linear bearing (1065)	2	S	WHITE bowden tube clamp (1069)	1
I	hex nuts 3mm (1209)	5	T	bowden tube (1266)	1
J	bolts M3 x 12mm (1203)	1	U	spacer 3mm (1545)	2
K	bolts M3 x 10mm (1202)	5	V	Small Fan (1512)	1
			W	black injection moulded part (1037)	1



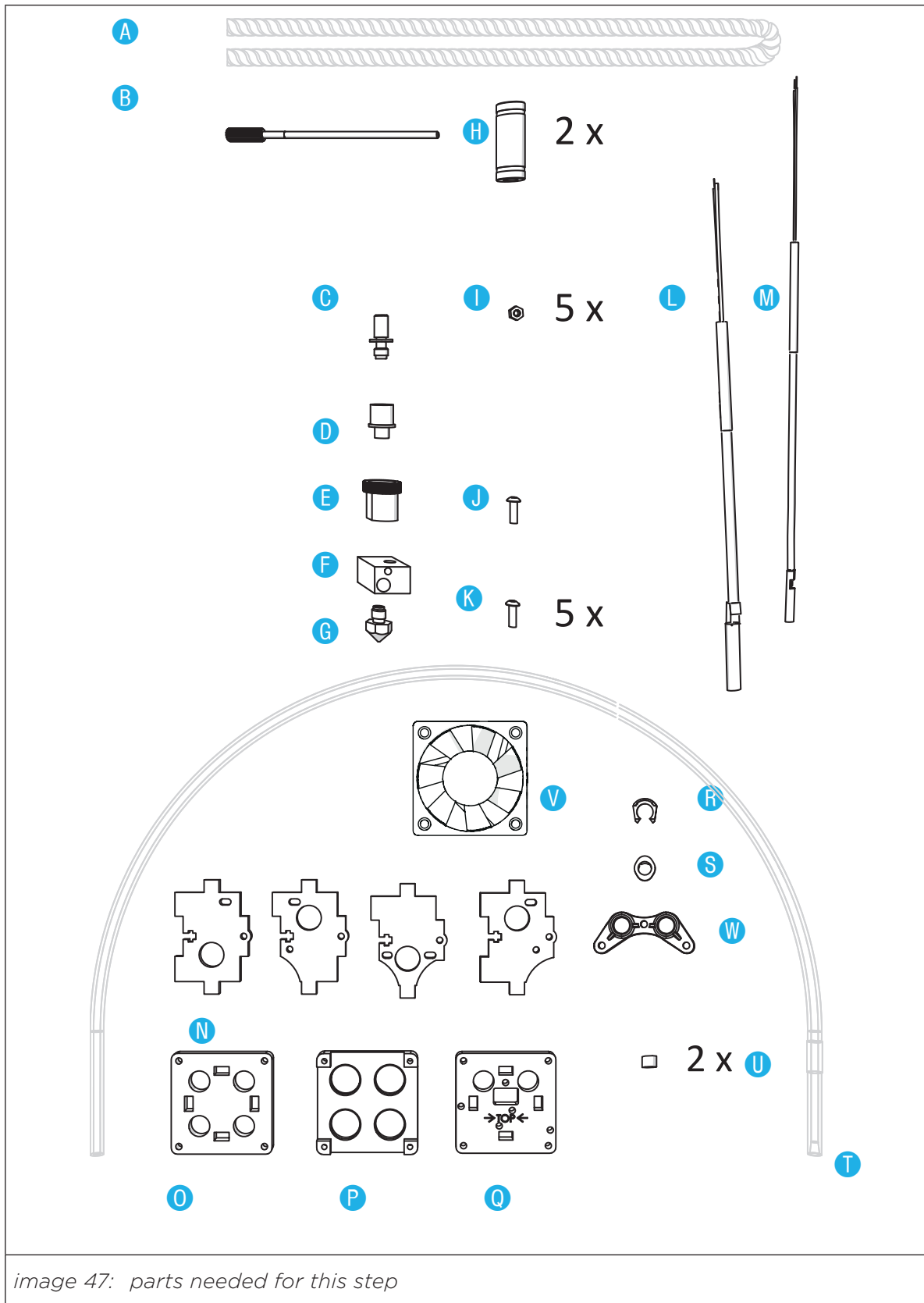

To assemble the extrusion head housing, perform the following actions.

1. Attach the nozzle into the aluminium heater block, see image 48.
i **NOTICE:** Attach the nozzle as tight as possible to the aluminium heater block.
2. Attach the brass pipe into the aluminium heater block. see image 48.
i **NOTICE:** A space between the brass pipe and the aluminium heater block is allowed, see image 49.

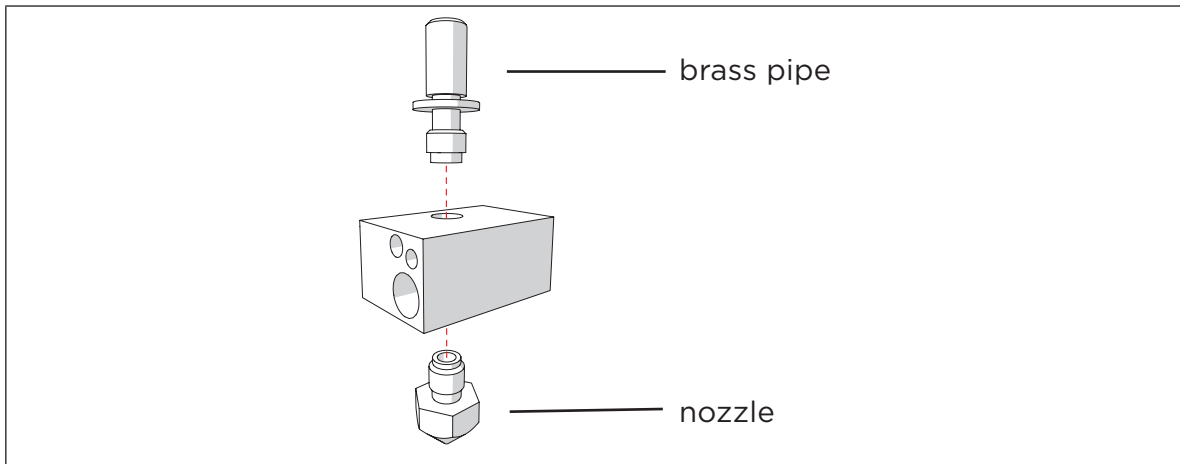

image 48: attaching the nozzle and brass pipe into the aluminium heater block.

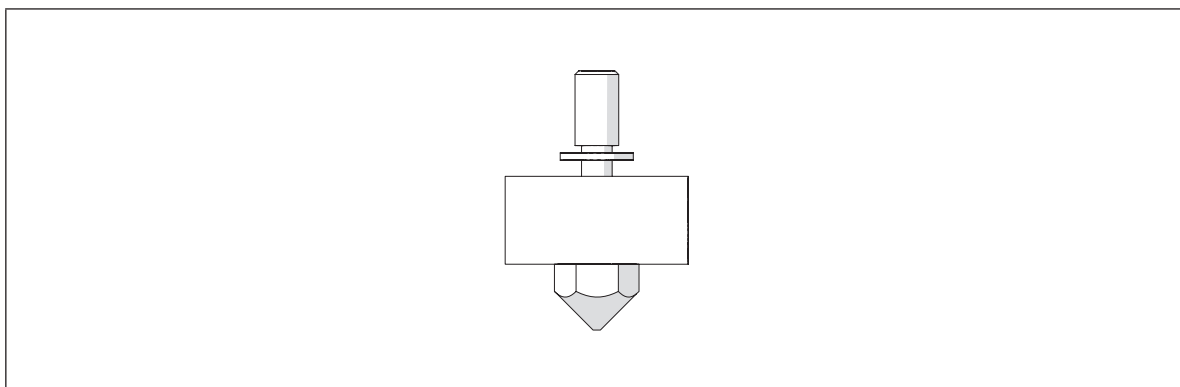

image 49: result assembling the nozzle, brass pipe and aluminium heater block.

3. Place one linear bearing in the FRONT and the BACK sides of the extrusion head housing, see image 50.
i **NOTICE:** make sure the linear bearing is sticking IN but NOT sticking THROUGH the sides.
4. Place one linear bearing in the RIGHT and the LEFT sides of the extrusion head housing, see image 50.
i **NOTICE:** make sure the linear bearing is sticking IN but NOT sticking THROUGH the sides.



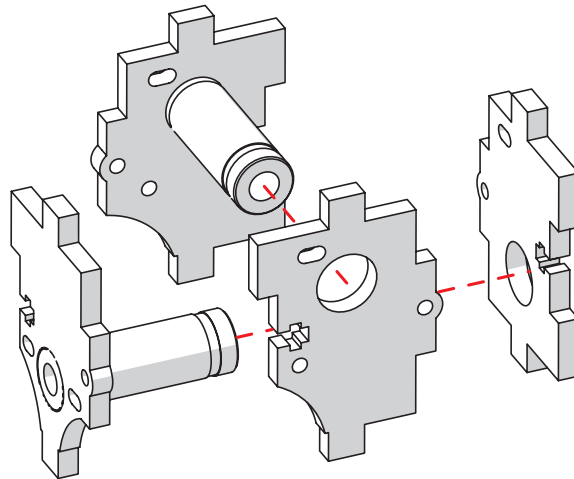

image 50: placing the linear bearings in the sides of the extrusion head housing

5. Place the extrusion head housing into the wooden part 8B, see image 51
6. Attach the sides together, see image 51.
Use four bolts M3 x 10mm and four hex nuts 3mm.

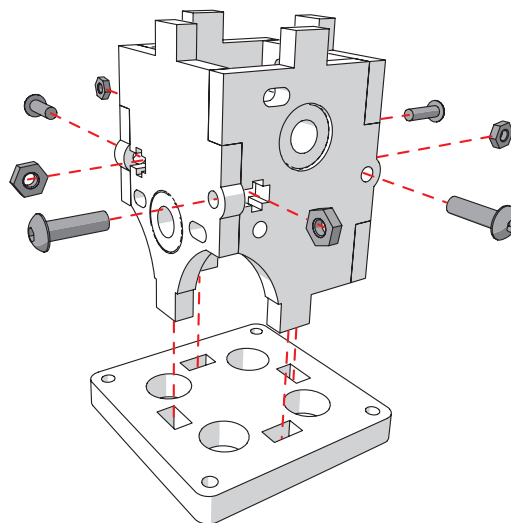

image 51: attaching the sides together and placing into wooden part 8B.

7. Place the peek into the aluminium plate, see image 52.
i **NOTICE:** the aluminium plate is symmetric. You can choose any hole you want.
8. Attach the peek into the brass pipe (keep the aluminium heater block in position as shown), see image 52.
i **NOTICE:** Attach the peek through the aluminium plate to the brass pipe as tight as possible. Be carefull not to break the brass pipe.



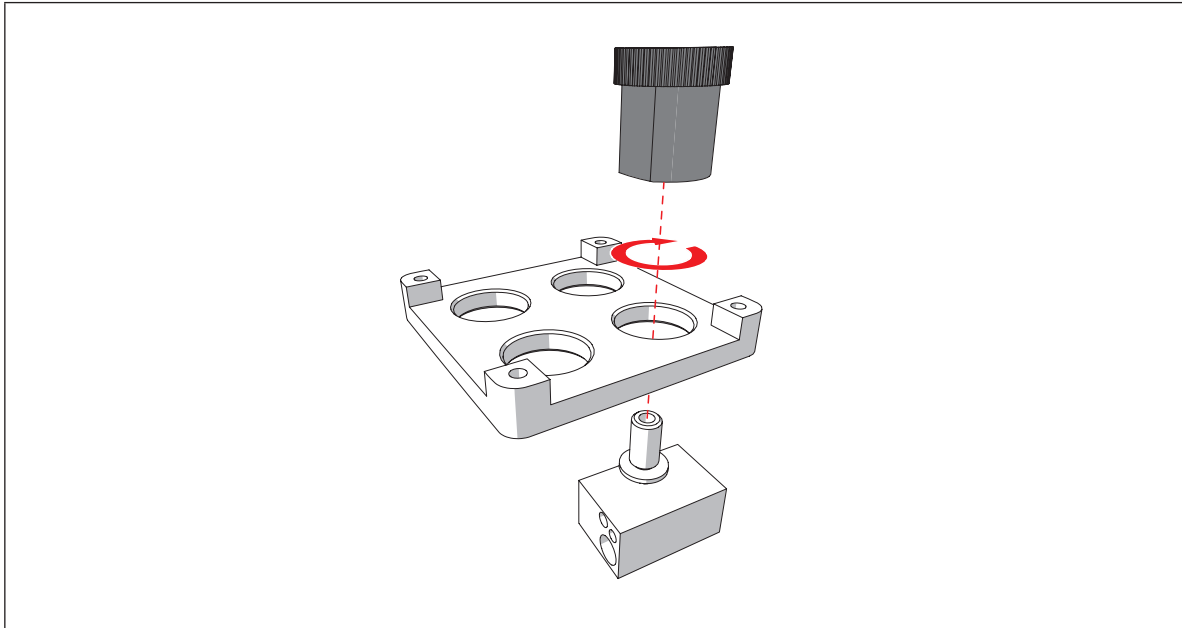

image 52: attaching the peek and the brass pipe through the aluminium plate

9. Thread the cartridge heater and the PT100 through the wooden part 8B, see image 53.



NOTICE: use the Front LEFT hole.



NOTICE: the cartridge heater is the small 6 mm cylinder with a right angle.



NOTICE: the PT100 is the small 3 mm cylinder with an aluminium sleeve.

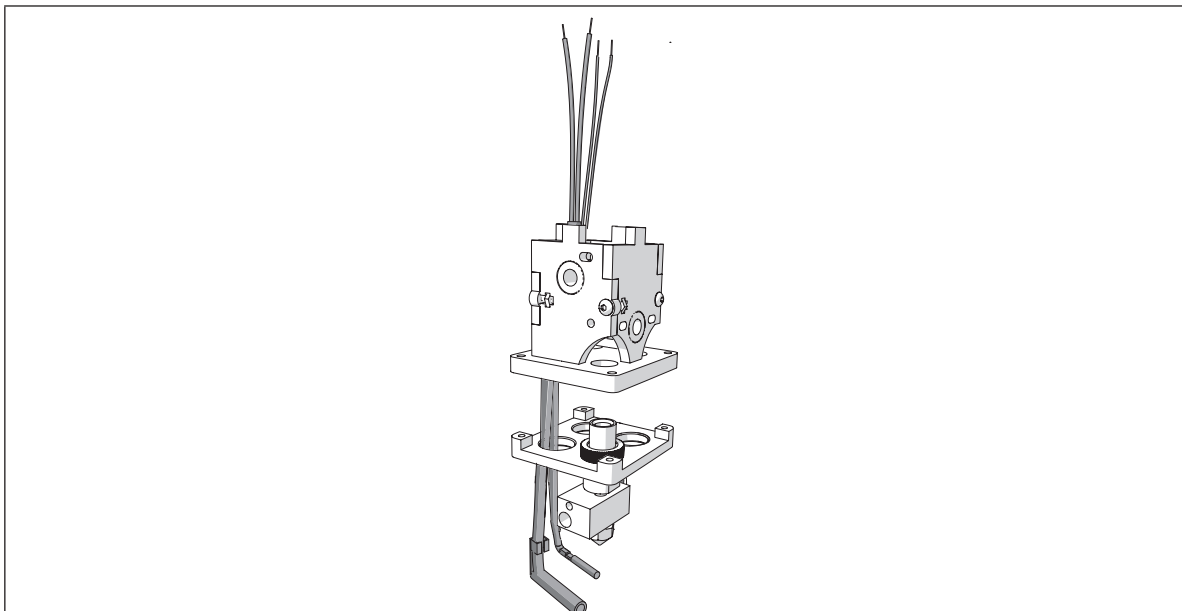

image 53: moving cartridge heater and PT100 through the aluminium plate and the extrusion head housing.



10. Attach the PT100 and cartridge heater in the back of the aluminium heater block, see image 54.
11. Lock the PT100 and cartridge heater.
Use ONE bolt M3 x 10mm.

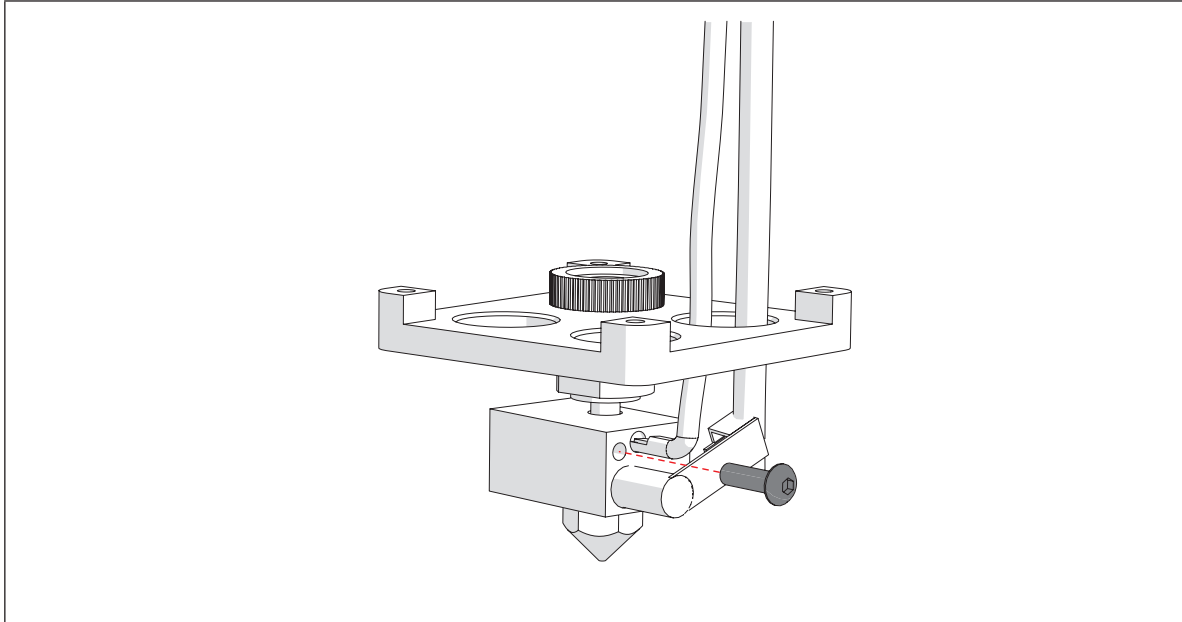

image 54: attaching the thermocouple and the cartridge heater

12. Insert the teflon coupler in the wooden part 8B, see image 55.

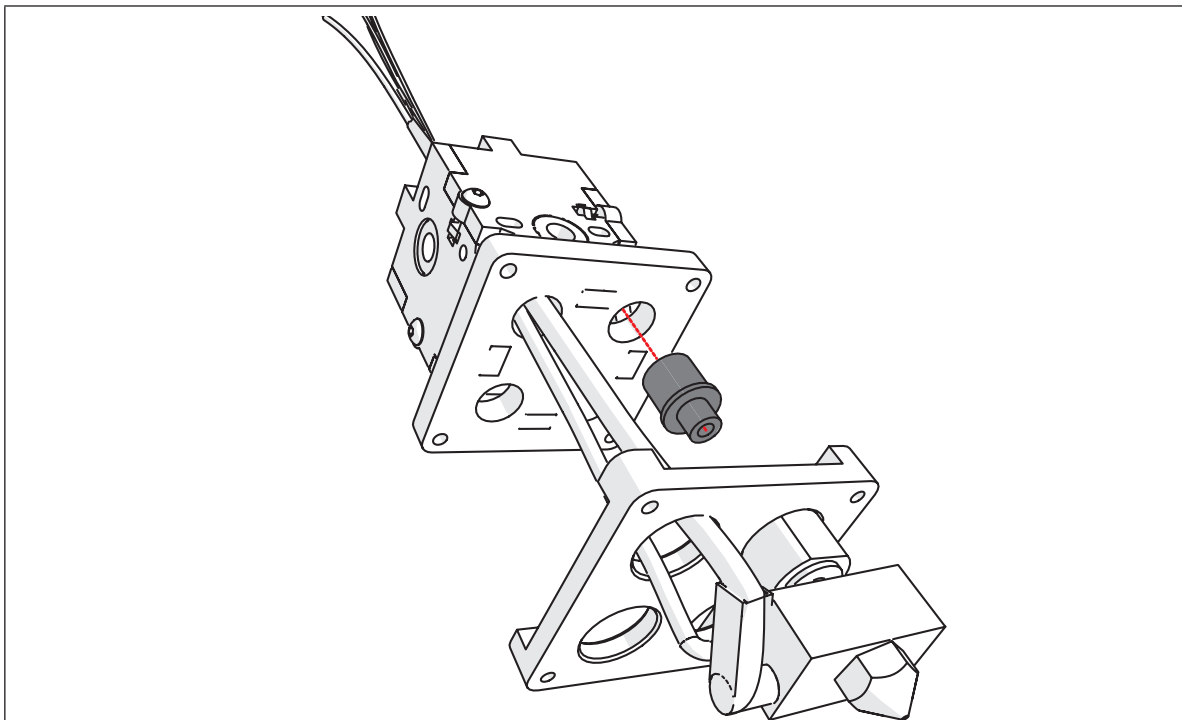

image 55: attaching the teflon tube



13. Attach the black injection moulded part on the wooden part marked TOP, see image 56.
Use ONE M3 x 12mm bolt and a hex nut.

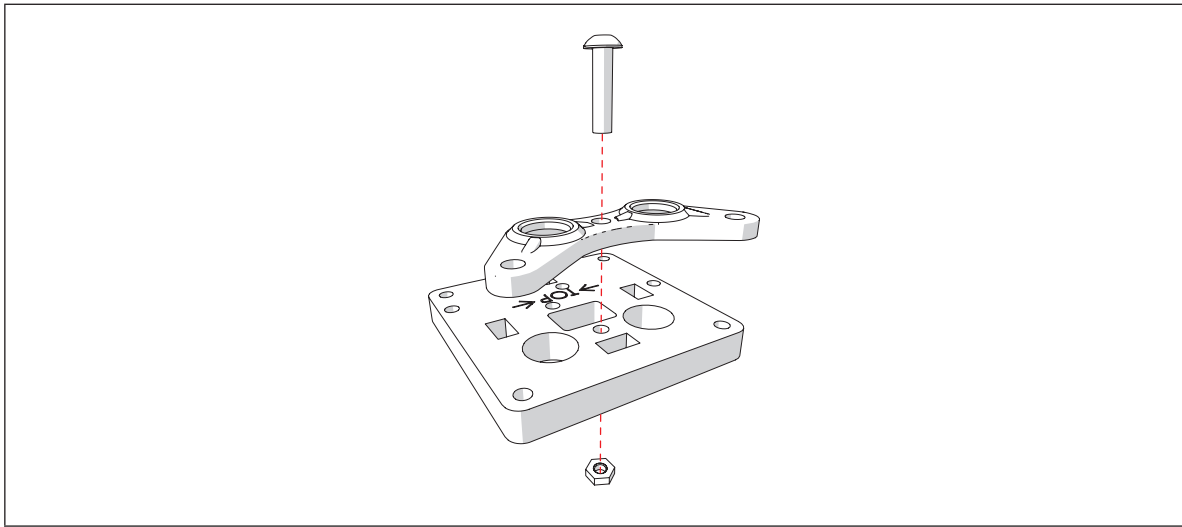

image 56: attaching the black injection moulded part on the wooden part TOP

14. Move the wires of the PT100, the cartridge heater and the small fan through the middle hole of the wooden part TOP, see image 57.
15. Place the Wooden top part on the rest of the assembly.

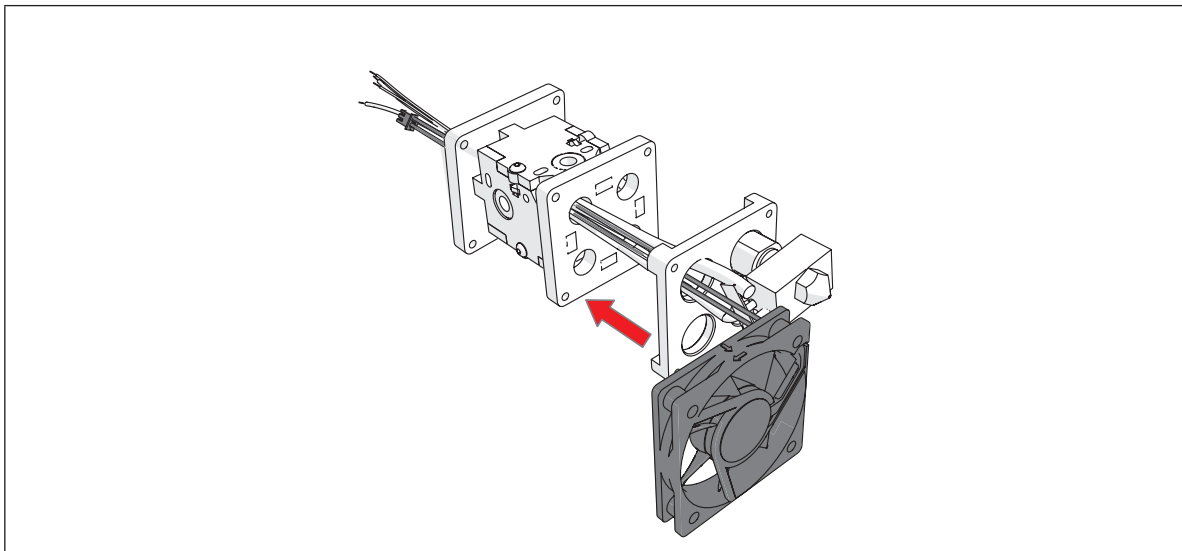

image 57: moving the wires of the thermocouple, cartridge heater and the small fan through the wooden part TOP

- (for action 20-22 see image 58)
16. Attach WHITE bowden tube clamp in the front RIGHT hole of black injection moulded part.
 17. Place 2x 3mm spacers around the 2 LONG studding bolts that don't go



- through the black injection molded part.
18. Move the LONG studding bolts through the corner holes.
 19. Attach the LONG studding bolts. Do not attach the LONG studding bolts too tight.

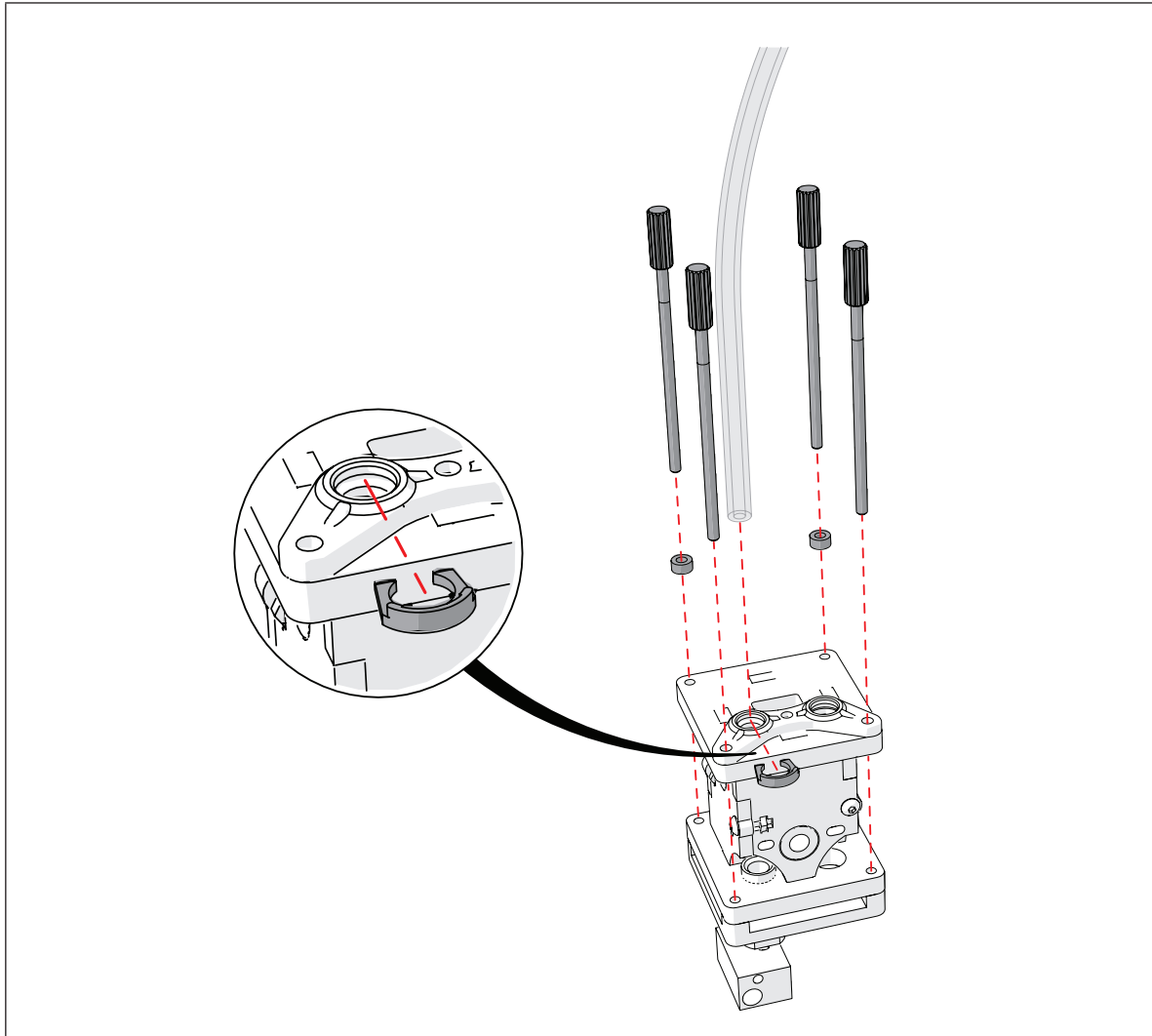

image 58: Attaching the WHITE bowden tube clamp and the long studding bolts.

- i** **NOTICE:** keep a small gap between the wooden part and the aluminium plate.
20. Move the bowden tube through the WHITE bowden tube clamp and into the teflon coupler.
- i** **NOTICE:** use the end of the bowden tube which has no blue tape.
Tip: you can use a screwdriver to guide the bowden tube into the teflon coupler, this might be a bit tricky.
21. Lock the bowden tube, by putting the blue horse shoe under the WHITE bowden tube clamp, see image 58.
- i** **NOTICE:** give some light pressure on the bowden tube while placing the blue horse shoe.



22. Tighten the long studding bolts completely.

6.3.2. Step 2: cooling fan assembly

The following parts are needed in this step.

Letter	Description	Qty.	Letter	Description	Qty.
A	Metal Fanduct (1501)	1	C	bolts M3 x 16mm (1204)	2
B	Bolt M3x4mm (1348)	2	D	Self Tapping Bolts (1362)	2

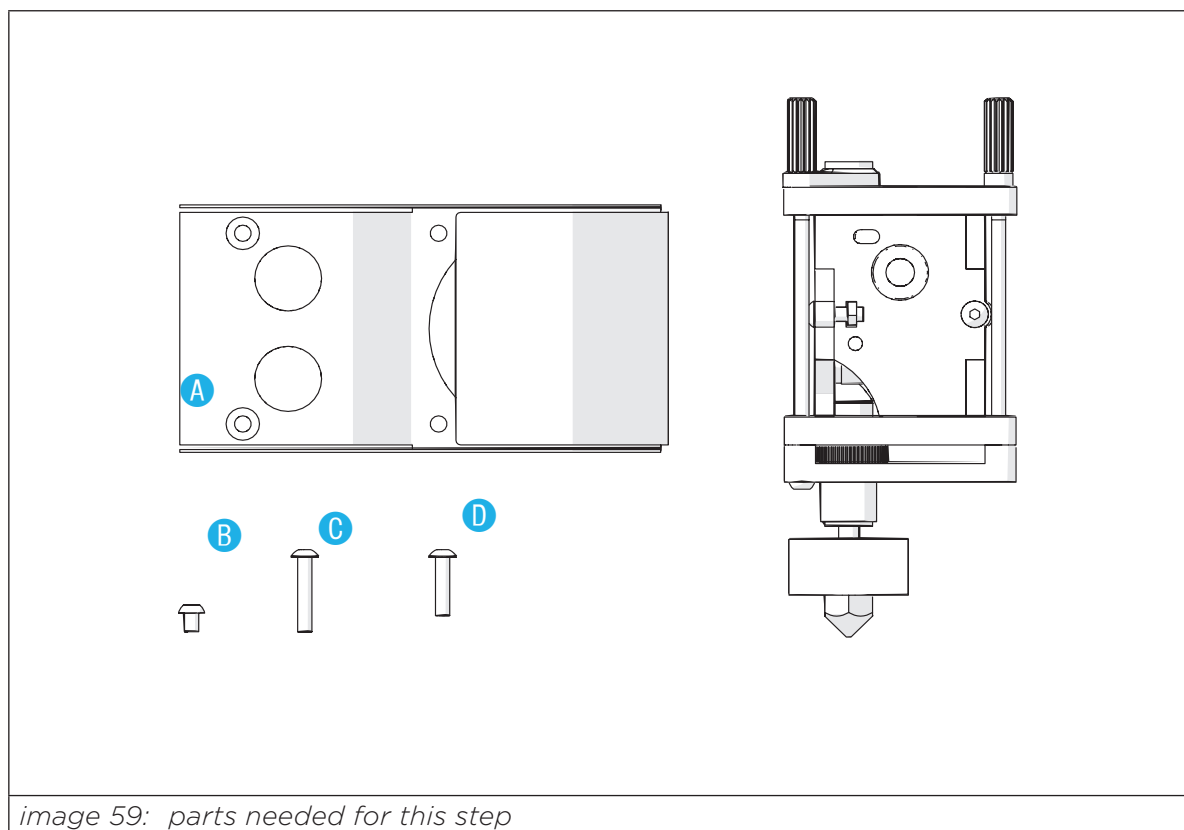

To assemble the cooling fan assembly, perform the following actions.

1. Take the Metal fanduct and place it around the heaterblock. See image 60
2. Use the 2x M3x4mm bolts to lock it into place by screwing them into the aluminium plate of the hot end assembly. The fancap screws into the bottom of the hotend.
3. Position the fan correctly between the metal fancap and the hotend. with the sticker facing downwards.
4. Use the 2x M3x16mm bolts to screw it into the aluminum plate of the hotend assembly. See image 61
5. Secure the fan to the metal fancap by using the 2 self tapping screws.



See image 62

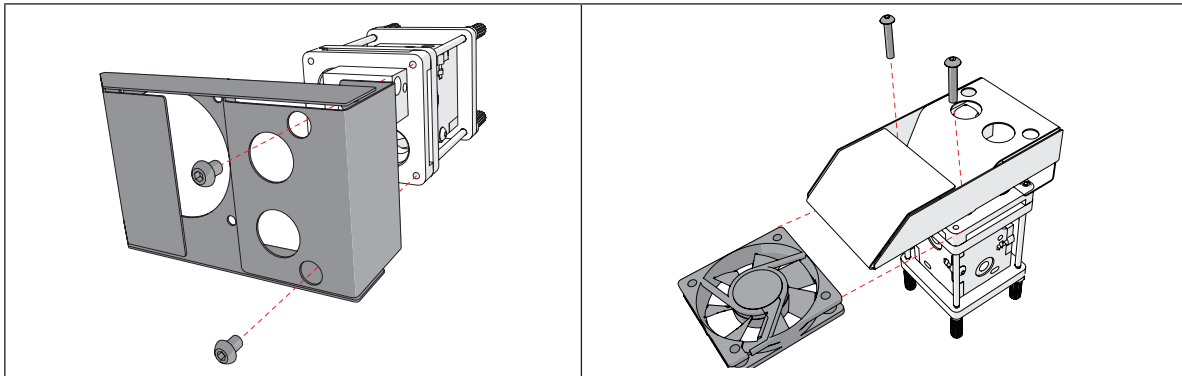

image 60: attaching the front of the fancap

image 61: attaching the back of the fancap and fan.

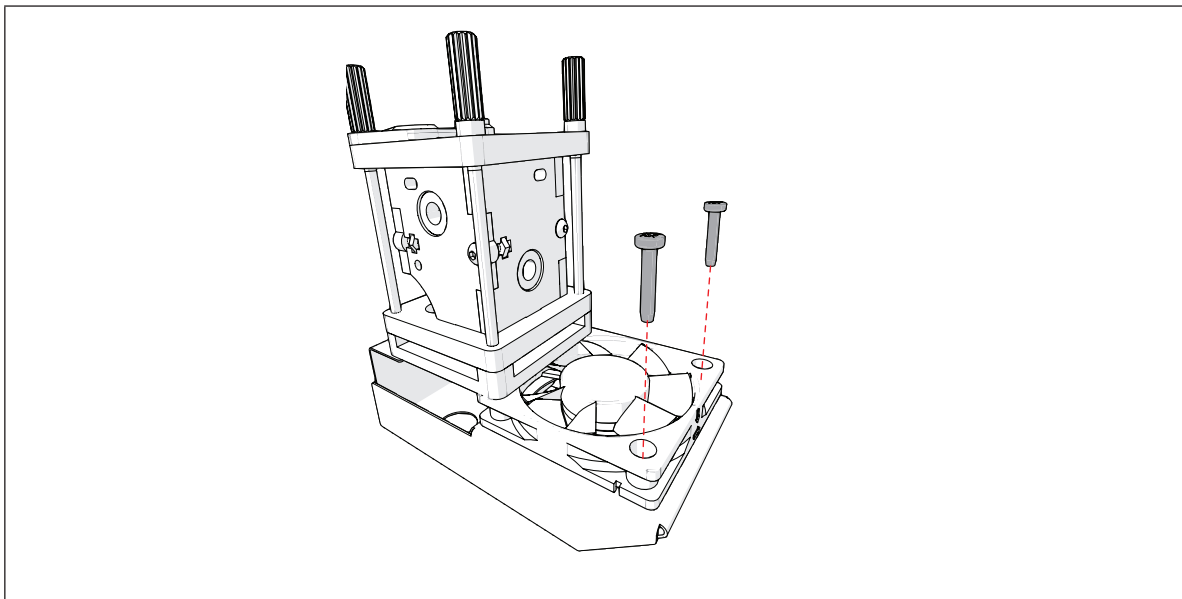

image 62: attaching the fan to the metal fan duct.



6.3.3. Step 3: attaching the housing on the XY frame

The following parts are needed in this step.

Letter	Description	Qty.	Letter	Description	Qty.
A	X and Y axes (1046)	2	D	wooden parts C (1504)	4
B	bolts M3 x 30mm (1208)	4	E	Calibration sticks (1530)	2
C	hex nuts 3mm (1209)	4			

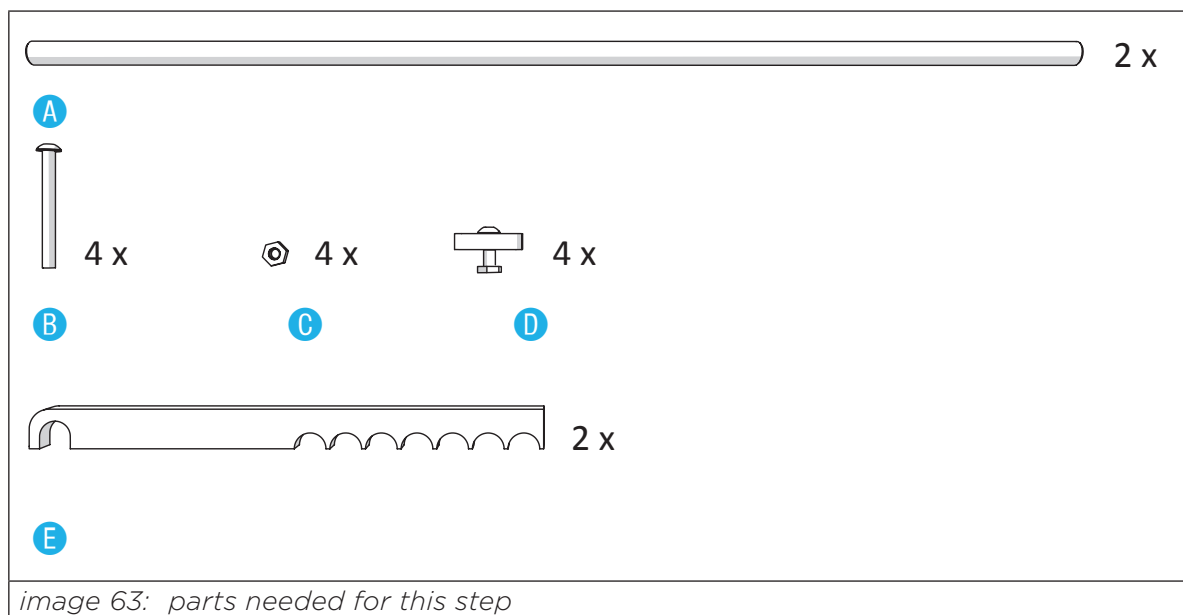

To attach the housing on the XY frame, perform the following actions.

1. Place a wooden part C into the LEFT slider block, see image 64.

i **Notice:** do not tighten yet.

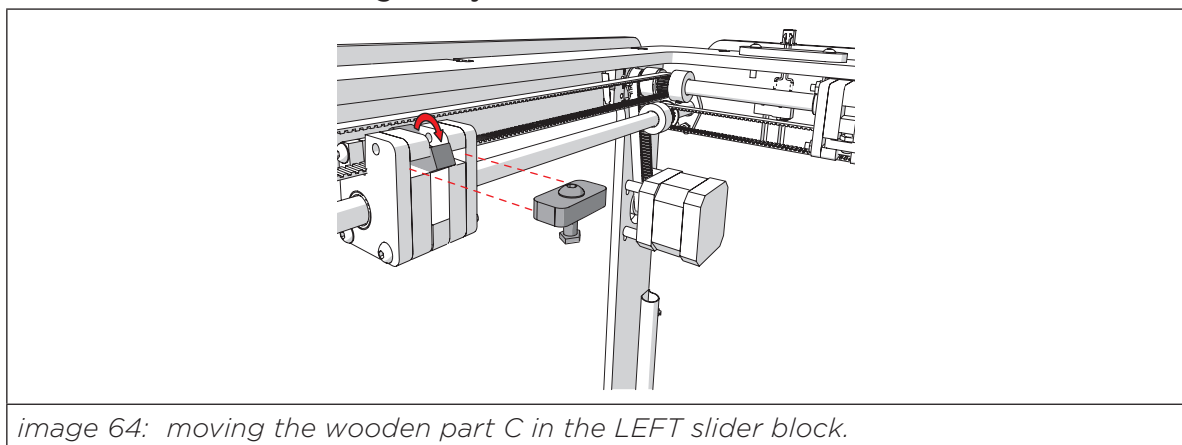

2. Move X and Y axes in the extruder head, see image 65.

i **Notice:** make sure the extruder head is placed inside the machine,



below the slider blocks.

- i** **Notice:** make sure the FRONT side of the extruder head is faced to the FRONT panel.

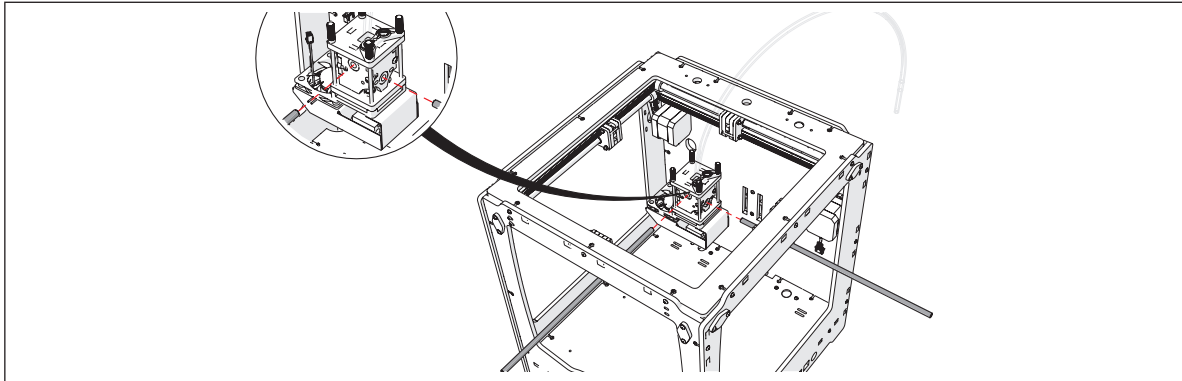

image 65: moving the X and Y axes into the extruder head

3. Move the X axis in the LEFT slider block, see image 66.
- i** **Notice:** make sure the Y axis do not fall out.
4. Move the Y axis in the FRONT and BACK slider blocks, see image 66.
5. Tilt the RIGHT slider block for.
6. Move the X axis in the RIGHT slider block.
- i** **Notice:** make sure the X and Y axis are placed in the right order in the slider blocks to prevent the X and Y axis from bending.
7. Move the wooden part C in FRONT, BACK and RIGHT slider blocks.
8. Attach ONE bolts M3 x 30mm in each FRONT, BACK and RIGHT slider blocks, see image 67.
- i** **Notice:** do not tight the bolts M3 x 30mm yet.
9. Tighten the wooden parts C.
10. Tighten the bolts M3 x 30mm
- i** **Notice:** Do not force. Make sure the X and Y axis do not bend.

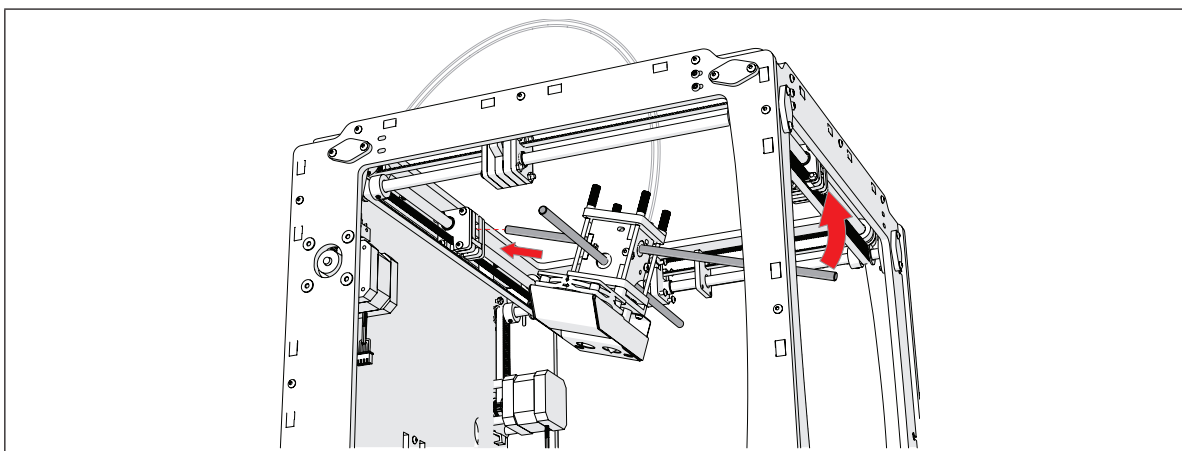

image 66: moving the X and Y axis into the slider blocks



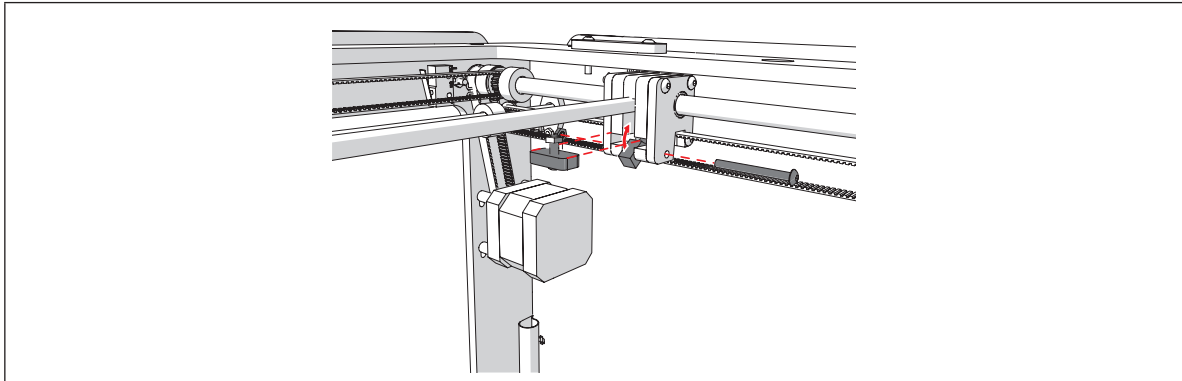

image 67: moving the wooden part C into the FRONT, BACK and RIGHT slider block and attach with ONE bolt M3 x 30mm

To calibrate the XY-gantry perform the following steps:

11. Align the X axis of the extruder head.
Use two Calibration sticks.
12. Tighten the timing pulleys which are attached to the LEFT timing belt, see image 68 and 69.
- i** **NOTICE:** make sure the calibration sticks use the same notch. Move the RIGHT sliderblock in the correct position if needed.
13. Tighten the timing pulleys which are attached to the RIGHT timing belt.
- i** **NOTICE:** use another notch if the timing pulleys can not be reached.
14. Repeat step 12 and 13 for the FRONT timing pulley and BACK timing pulley. This will calibrate the axis.

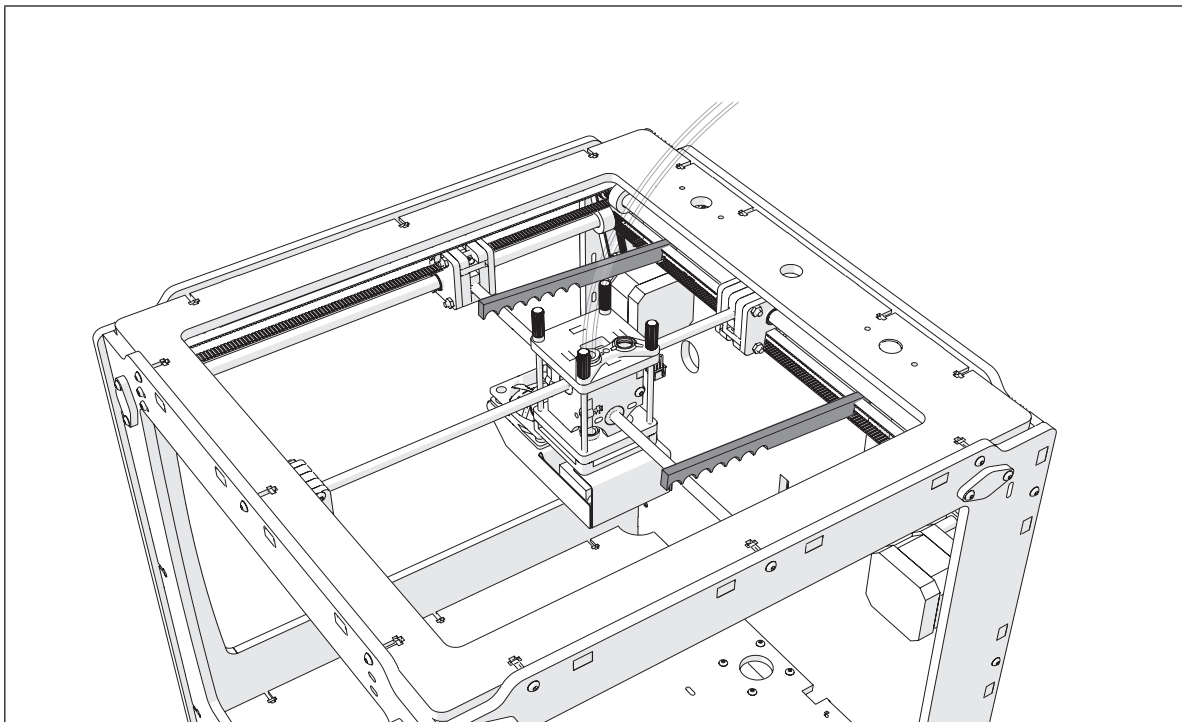

image 68: tightening the timing pulleys by using Calibration sticks



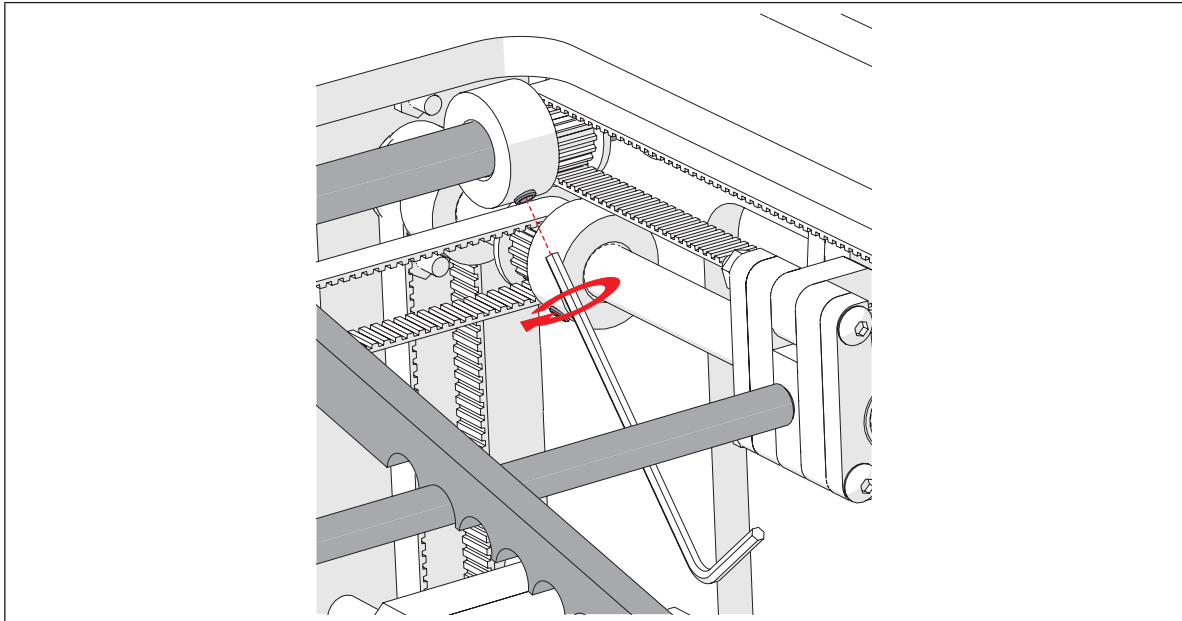

image 69: adjusting the timing pulleys

15. Move the Y motor down and keep it in position.

i **Notice:** push gently, do not overdo.

16. Tighten the bolts, see image 70

17. Repeat step 15 and 16 for the X motor.

i **Notice:** Check if all the Belts are vertically straight and not moving diagonally. if so, align the pulley

i **Notice:** Check if everything is running smoothly. If not, the pulleys or belts might be hitting the side of the case. make sure they have some room.

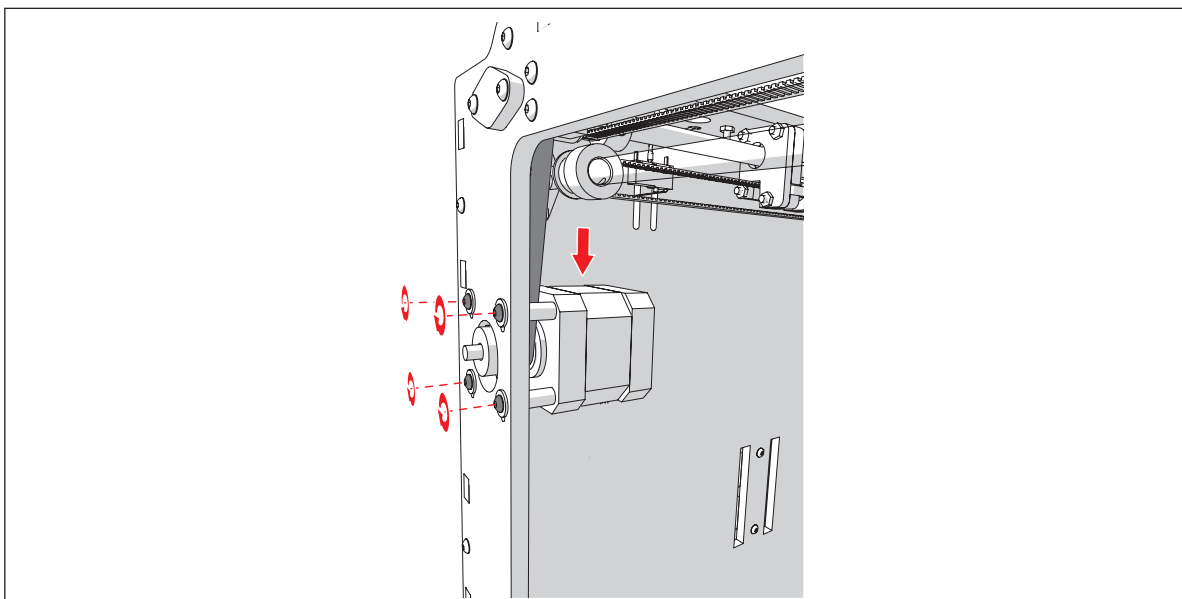

image 70: tightening the bolts of the Y motor.



6.3.4. Step 4: Aligning the X-Y Switches.

1. Move the X-switch as far right as possible and the Y-switch as far back as possible and tighten down the screws
2. Move the extruder head to the front left corner of the machine.
i **Notice:** Make sure you hear the limits switch clicking.
3. Make sure it is in the corner of the machine but not touching the frame itself.
i You can tune a little more build volume if you move both the switches towards the Front left corner. Always make sure not to hit the frame when doing this.



6.4 ASSEMBLING THE Z STAGE

WHAT YOU'LL NEED TO
ASSEMBLE THE Z-STAGE.

Time:

about 60 to 90 minutes

Tools:

hex keys (2mm)

hex keys (2,5mm)

small flat screwdriver (1,5mm)

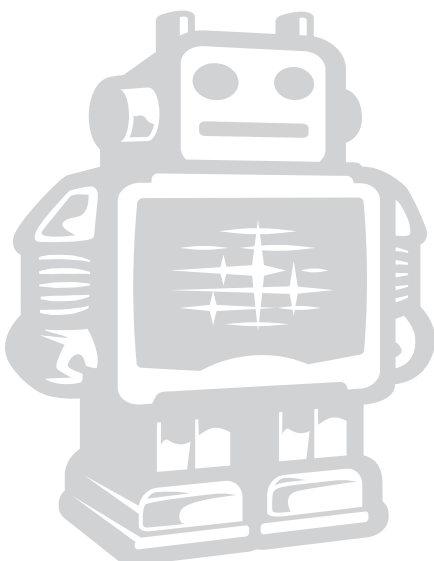

6.4.1. Step 1: Assembling the Aluminium base plate.

The following parts are needed in this step.

Letter	Description	Qty.	Letter	Description	Qty.
A	Aluminium base plate (1818)	1	D	M4x10mm (1217)	8
B	Square Flanged Linear Bearing (1170)	2	E	M3x10mm (1202)	6
C	Z-lead nut (attached to the Z-motor) (1159)	1			

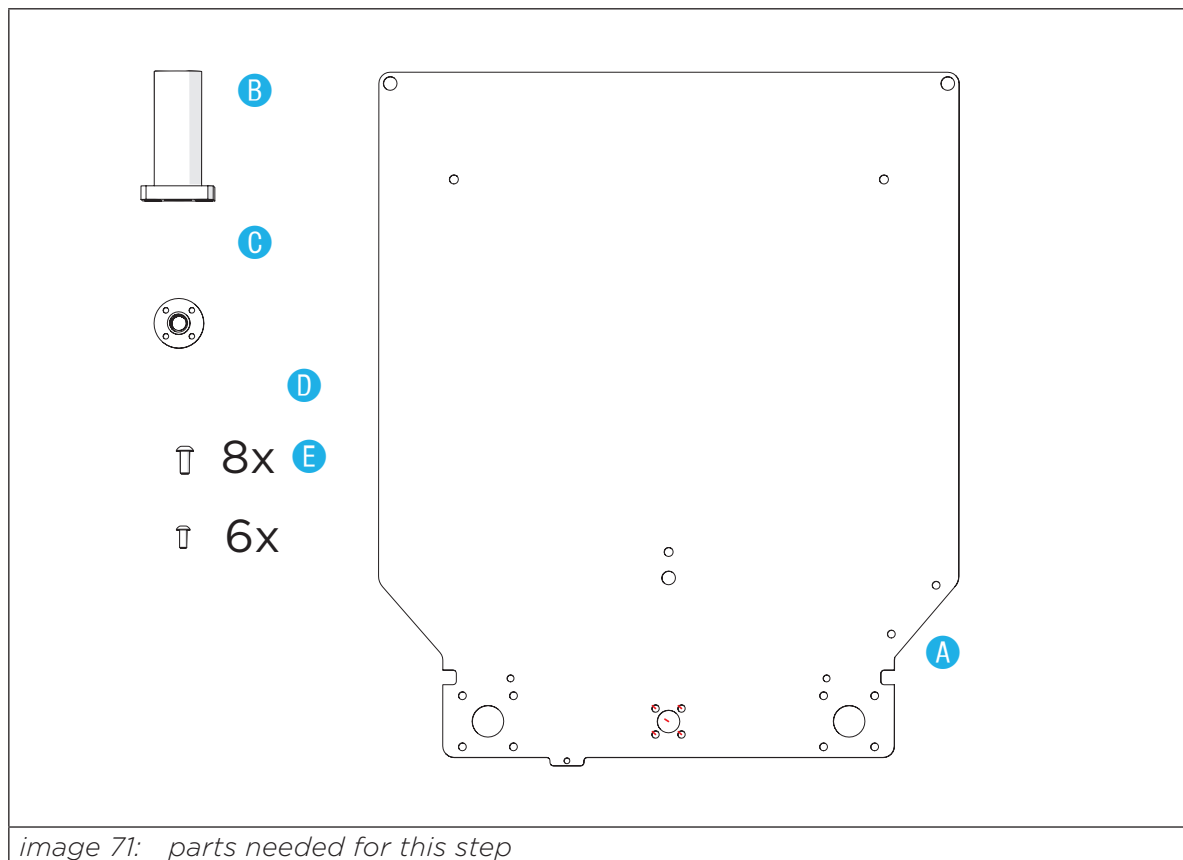

To assemble the Aluminium baseplate preform the following steps

1. Position the Aluminium plate as shown in image 72.
2. Place the 2 Linear Bearings over the holes in the back corners.
3. Secure them in place with 4x M4x10mm bolts per bearing.
4. Make sure the bearings are free to move around. this makes for easier calibration later on.
5. Place the Z-lead nut in the hole at the back of the aluminum plate. see image 73.
6. Flip the aluminium plate over and secure it into place with the 4 M3x10mm bolts



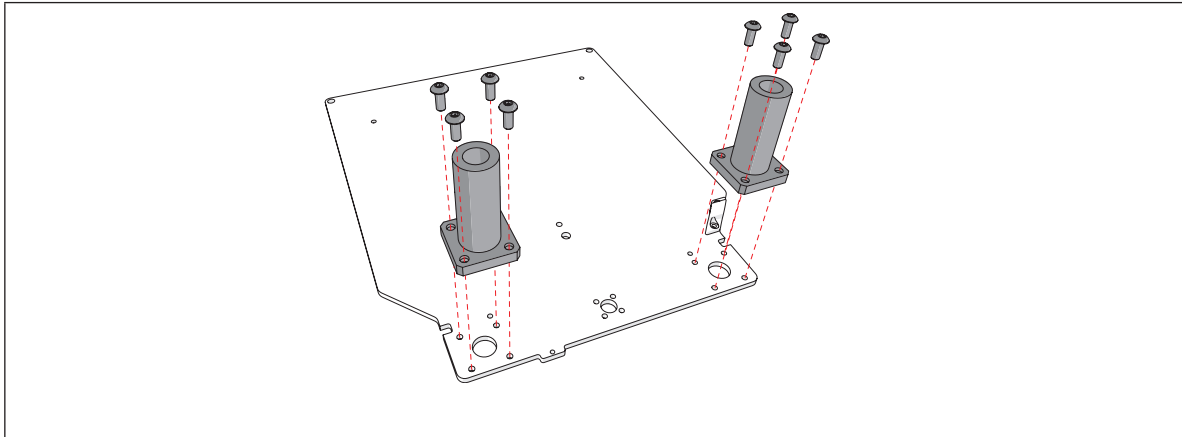

image 72: assembling the drive nut assembly.

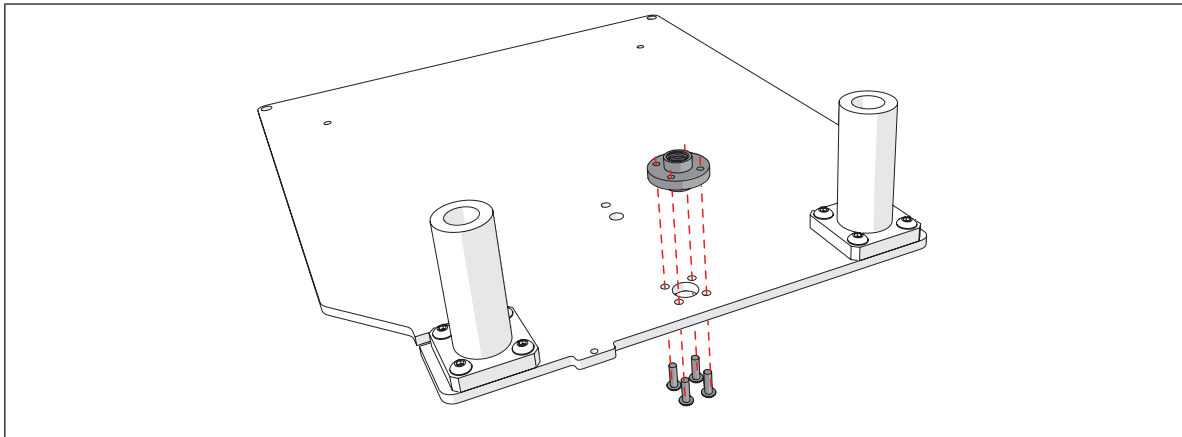

image 73: assembling the drive nut assembly.



6.4.2. Step 2: Assembling the Heated bed PCB

The following parts are needed in this step.

Letter	Description	Qty.	Letter	Description	Qty.
A	Heated bed PCB (1155)	1	D	Countersunk Bolts M3x8 (1215)	4
B	Glass Retainer Clip (1256)	2	E	Lock Nut M3 (1214)	4
C	Heated bed Cable (1183)	1			

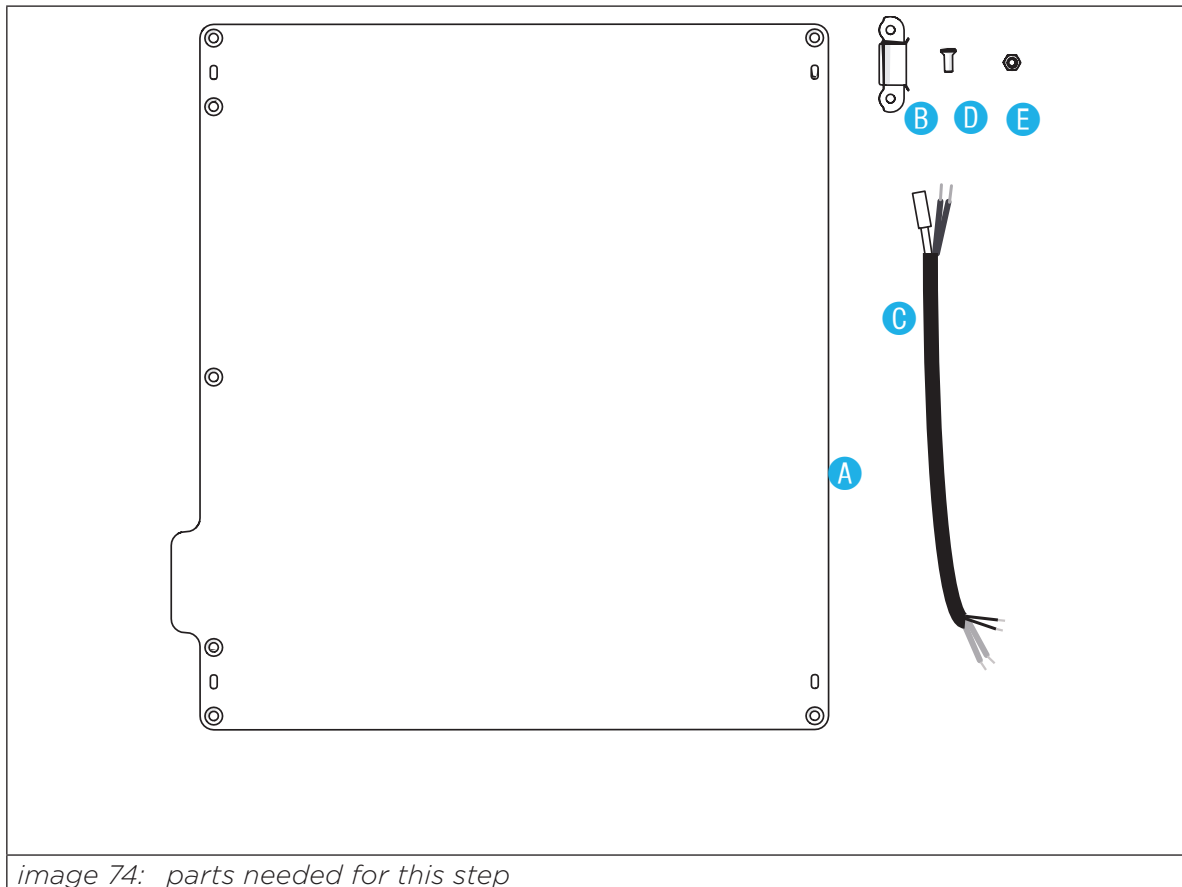

image 74: parts needed for this step

To assemble the Heated bed PCB, perform the following actions (

1. Take the 2 glass retainer clips and place them on the back side of the PCB. See image 75.
2. Use the 4x M3x8mm countersunk bolts and 4x M3 Locknuts to bolt it down.
3. Place the Heated bed PCB with the aluminum side down on a flat surface.
4. Connect the Heated bed cable to the Connector on the Heated bed. See image 76
5. The Gray (FAT) wires go on the right side and the black (THIN) wires go on the left side.



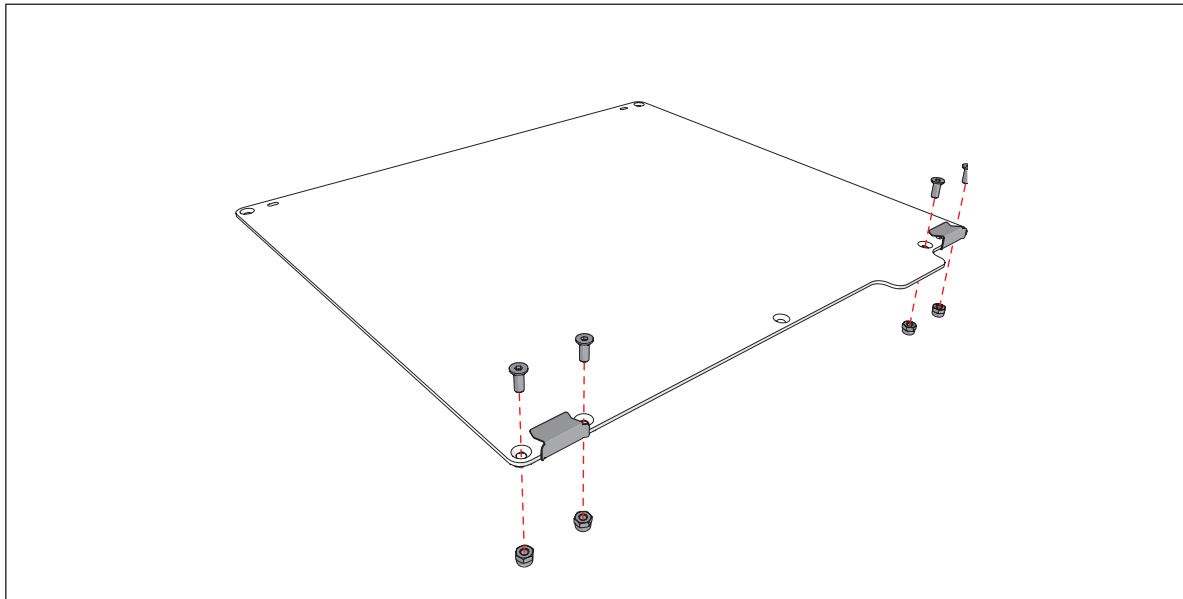

image 75: attaching the adjustable level screws



image 76: Connecting the Heated bed Cable.

⚠ Make sure the wires are screwed in tightly. This might otherwise lead to bad contacts or heated bed failure.



6.4.3. Step 3: Connecting the PCB to the Baseplate

Take the Subassemblies made in step 1 and 2. Together with the extra parts listed below.

Letter	Description	Qty.	Letter	Description	Qty.
A	Countersunk Bolts M3x20 (1216)	3	E	Washer M6 (1288)	3
B	Knurled Nut (1257)	3	F	Copper Grease (1524)	1
C	Table spring (1152)	3	G	Strain Relief clip (1243)	1
D	Glass retainer clip (1256)	2			

To connect the PCB to the baseplate, perform the following actions.
(for action 1-6 see image 77.)

1. Take the M6 Washers and the Copper grease. Put the Copper grease on the convex(round) side of the washers.
2. Place the washers over the knurled nut with the grease upwards.
3. Place the Knurled nuts through the Front left, Front Right and Back middle holes in the aluminium baseplate.
4. Put the 3 Table springs over each of the Knurled nuts, place a glass retainer clip on top of it and place the Heated bed PCB on top. See image 77
5. Take the 3x M3x20mm countersunk screws and place them through the 3 holes in the PCB.
6. Take the cableclip and 2x m3x10mm bolts and secure the Heated bed cable in place.
7. Slide the glass retainer clips open and take the glass plate and just slide it into the assembly. See image 78



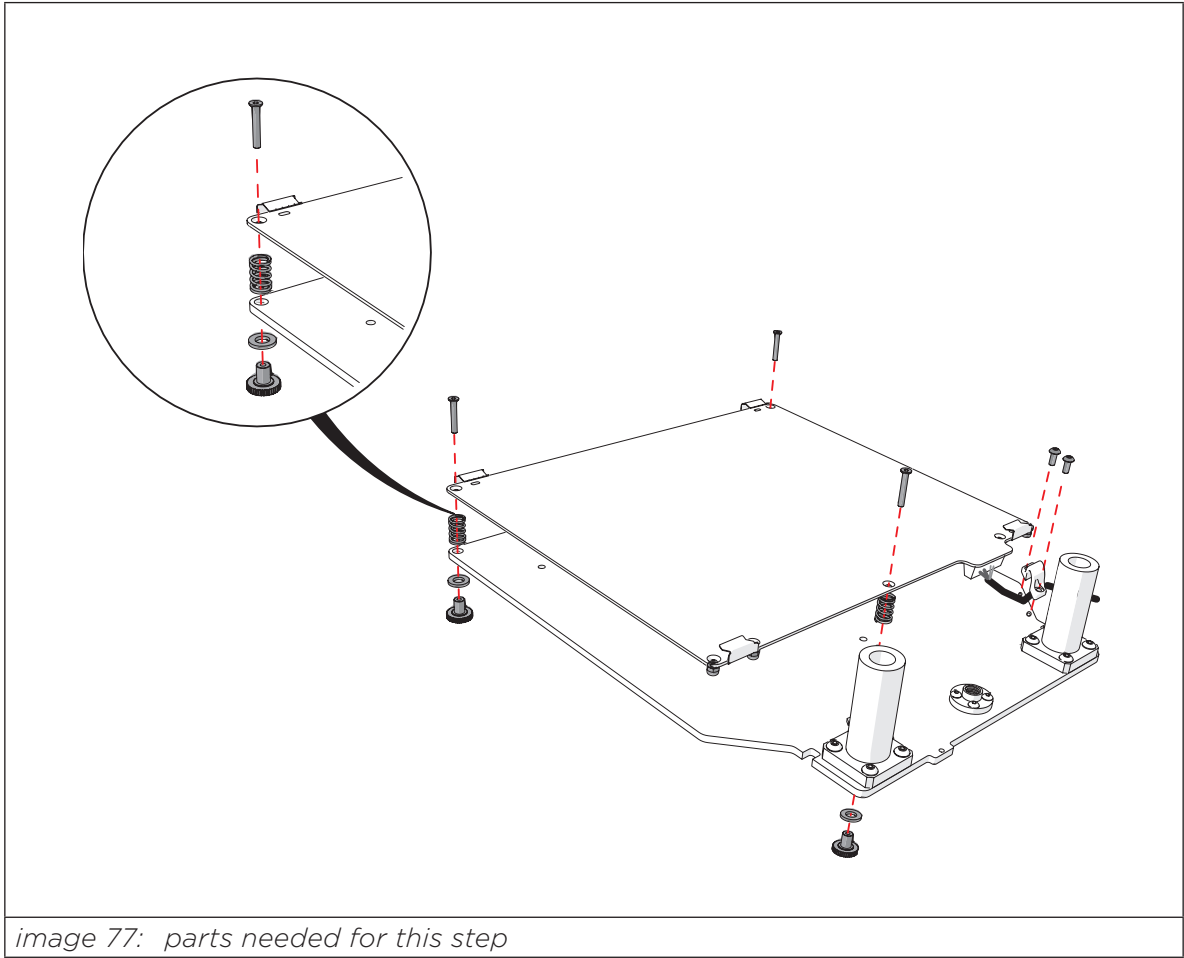

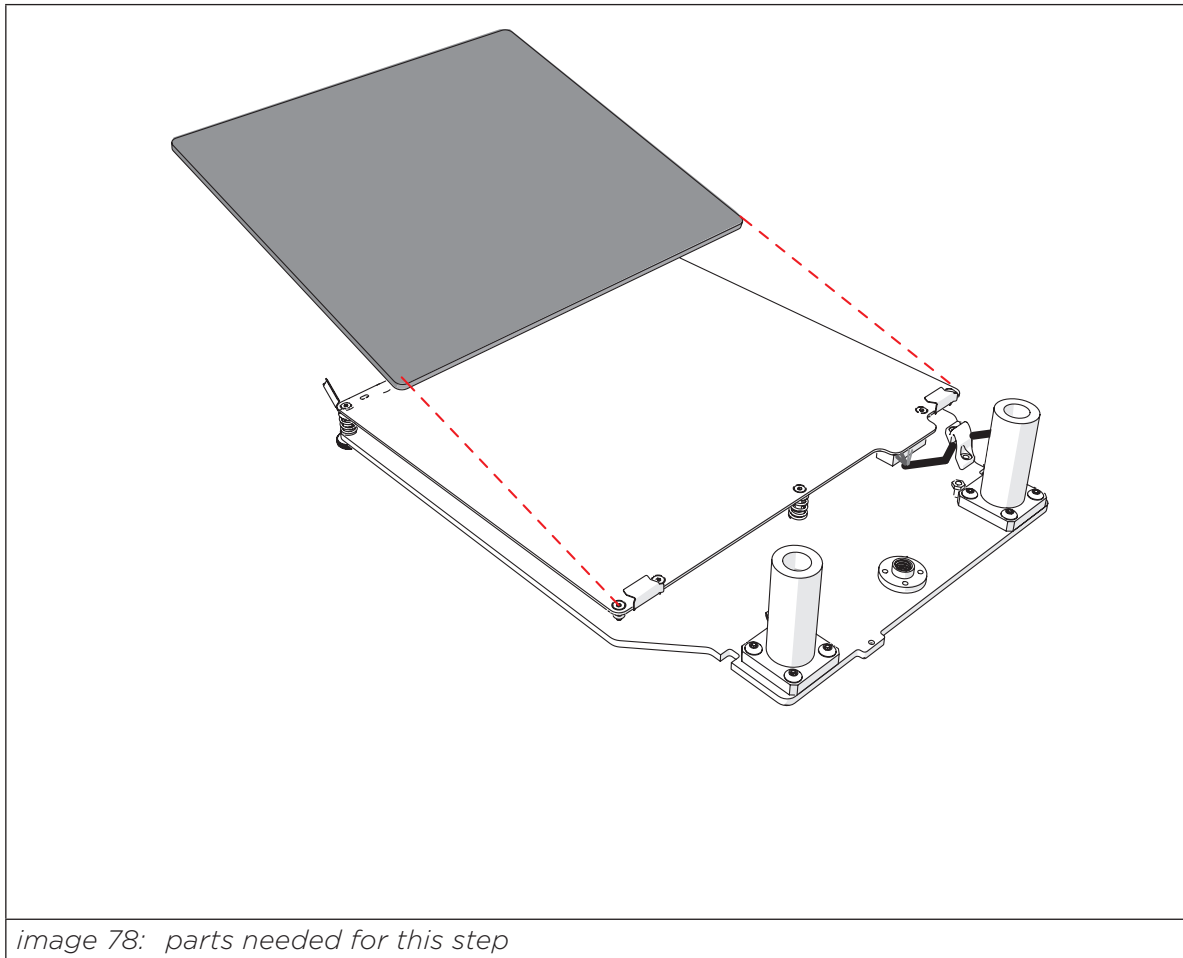

6.4.4. Step 4: finishing the Z stage assembly

The following parts are needed in this step.

Letter	Description	Qty.	Letter	Description	Qty.
A	Main Wooden part 6mm (1505)	1	E	Hex nut (1209)	10
B	Wooden middel part 4mm (1508)	2	F	M3x14mm bolt (1205)	4
C	Wooden Left part (1506)	1	G	M3x12mm bolt (1203)	6
D	Wooden Right part (1507)	1			



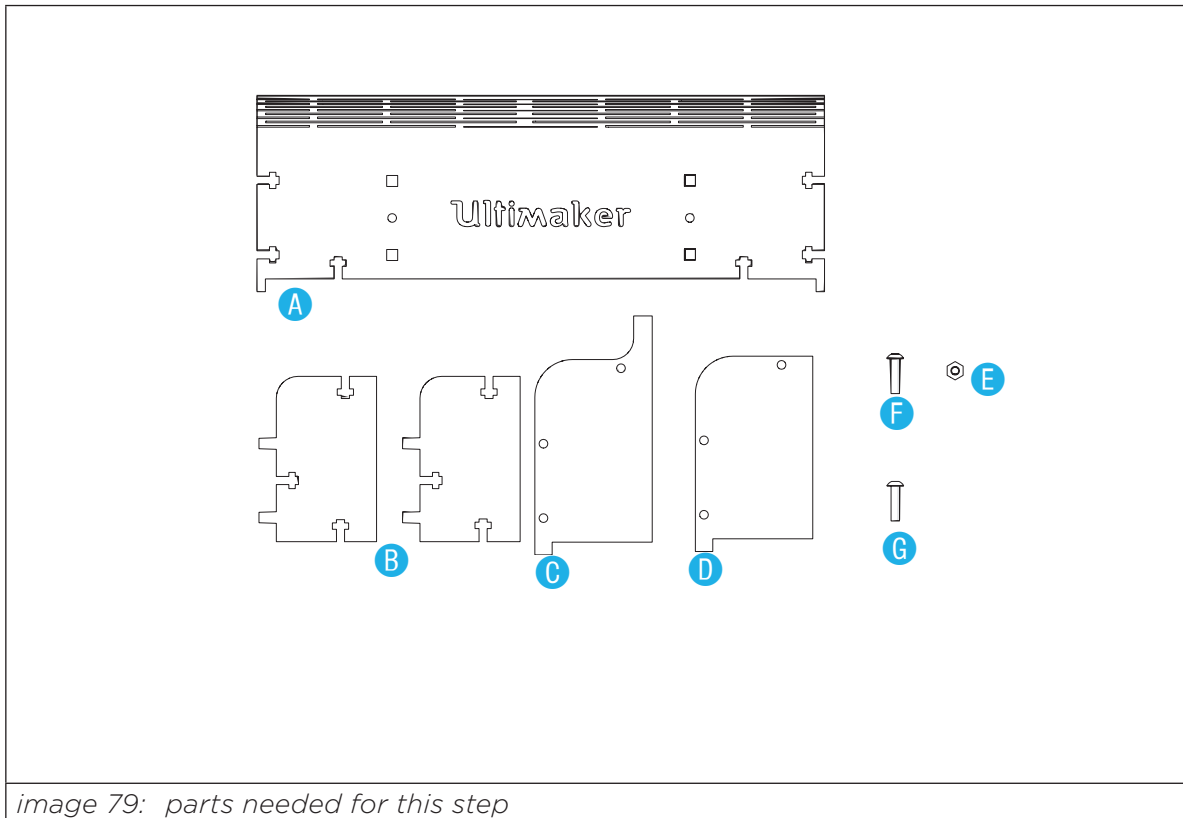

image 79: parts needed for this step

To assemble the Z-stage Cap perform the following actions.

1. Take the 6mm wooden part and place it facing down, so you can't read the word Ultimaker.
2. Take the wooden middle parts and place them into the middle slots.
3. Fold the 6mm wooden part 90 degrees and secure it in place with 4x M3x14 and 4x M3 nuts. See image 80.

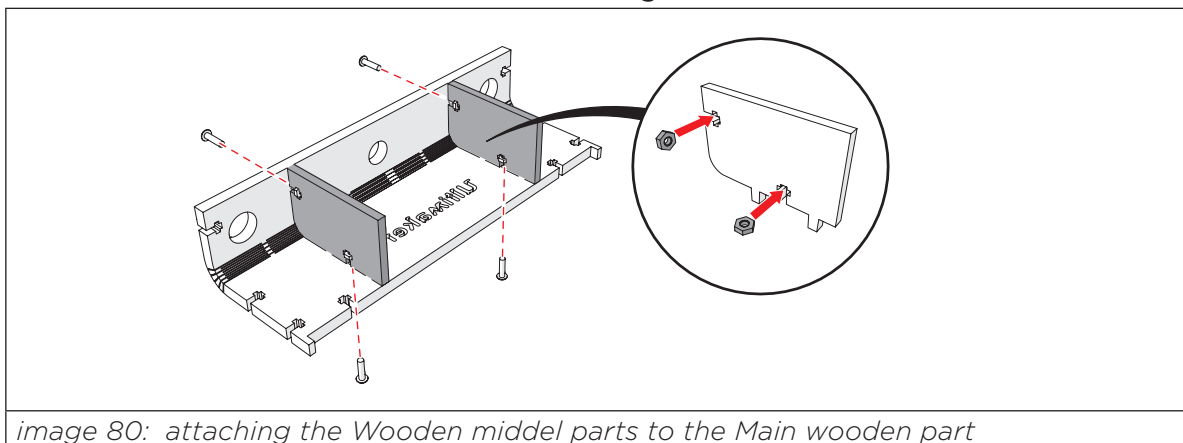
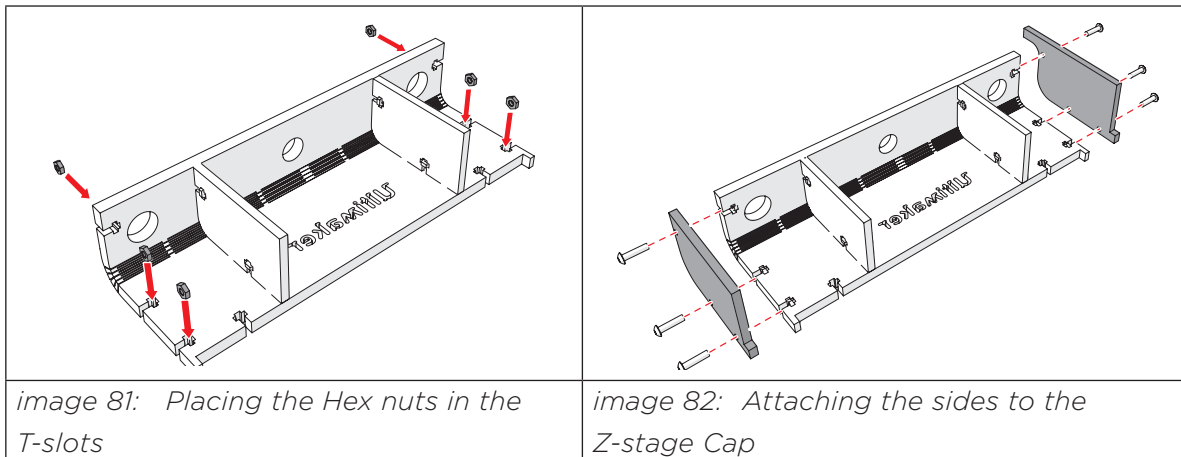

image 80: attaching the Wooden middle parts to the Main wooden part



4. Place the six hex nuts 3mm in the slots of the 6mm wooden panel. See image 81.
5. Place the 4mm wooden side parts on the Z stage cap. One side has the extra protruding part at the top. see image 82
6. Attach the parts together.
Use six bolts M3x12mm.



If done correctly, the result must look like this, see image 83. Attaching it to the bed will be done in a later stage.

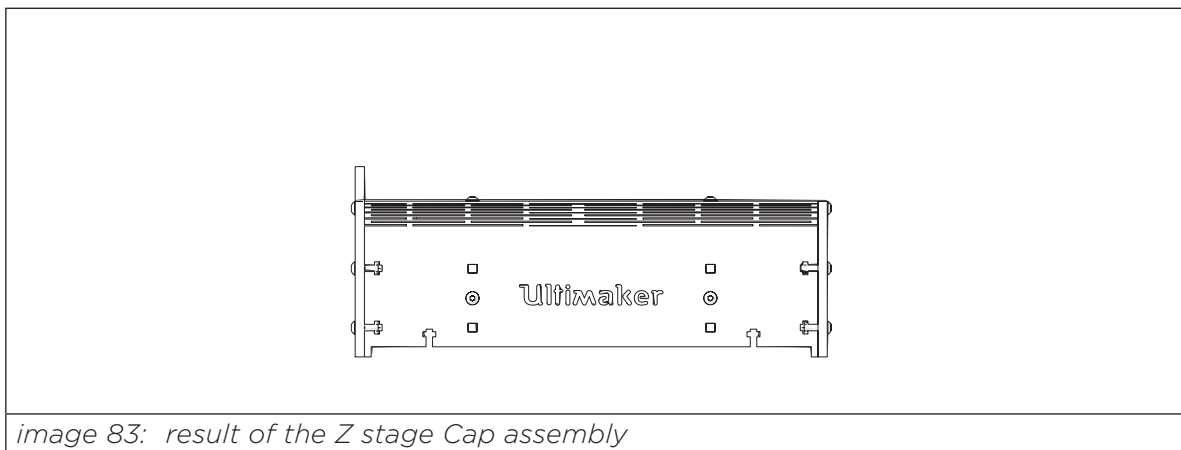

6.4.5. Step 6: installing the Z stage in the machine

The following parts are needed in this step.

Letter	Description	Qty.	Letter	Description	Qty.
A	Z-motor (1159)	1	E	bolts M3 x 16mm (1204)	6
B	Z stage cap	1	F	wooden parts 3B (1044)	2
C	12mm axes (1028)	2	G	Hex nuts (1209)	6
D	bolts m3x10 (1202)	4			

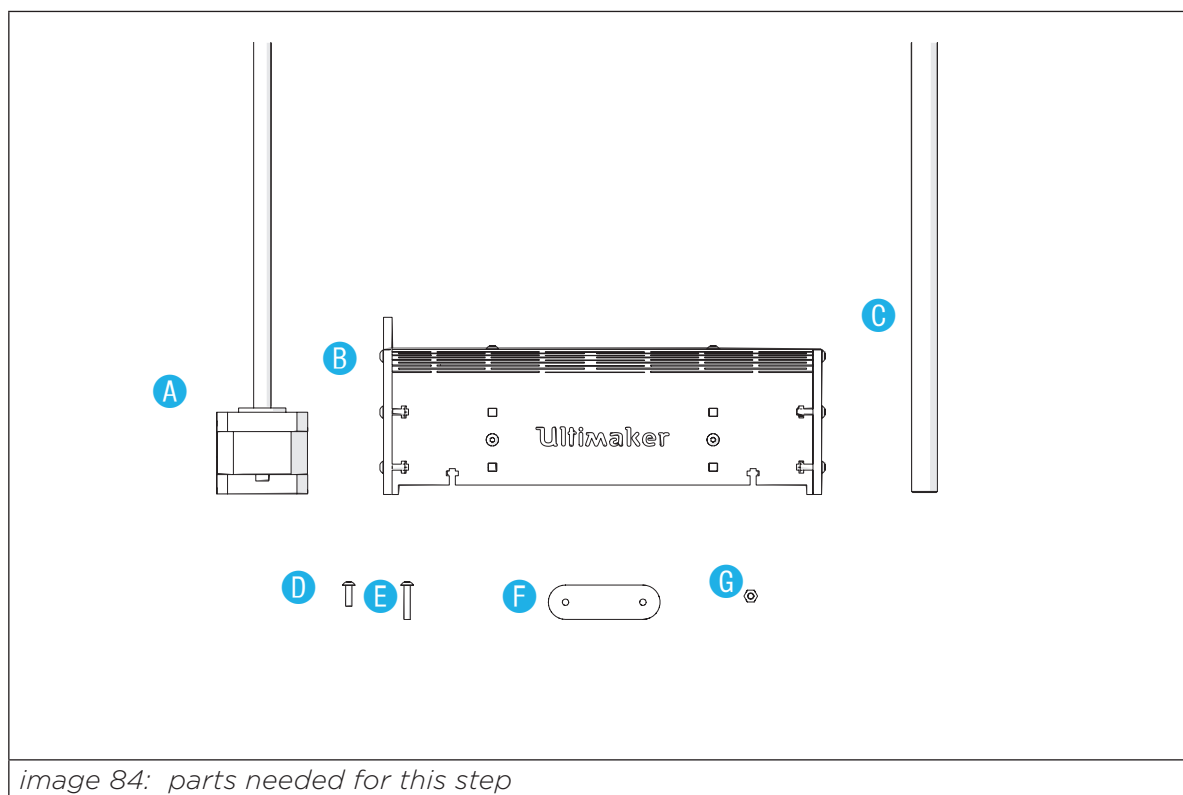

To install the Z stage in the machine perform the following actions.

1. Place the Z stage and the z-stage cap in the machine.
2. Move 12mm axis down through the TOP panel, the Z-stage cap and through the linear bearing of the Z stage, see image 85.
3. Move the 12mm axis further, through the BOTTOM panel, see image 85.
4. Do the same for the second 12mm axis, see image 85.
5. Attach wooden part 3B on top of the 12mm axes.
Use two bolts M3 x 16mm and two hex nuts for each wooden part 3B.



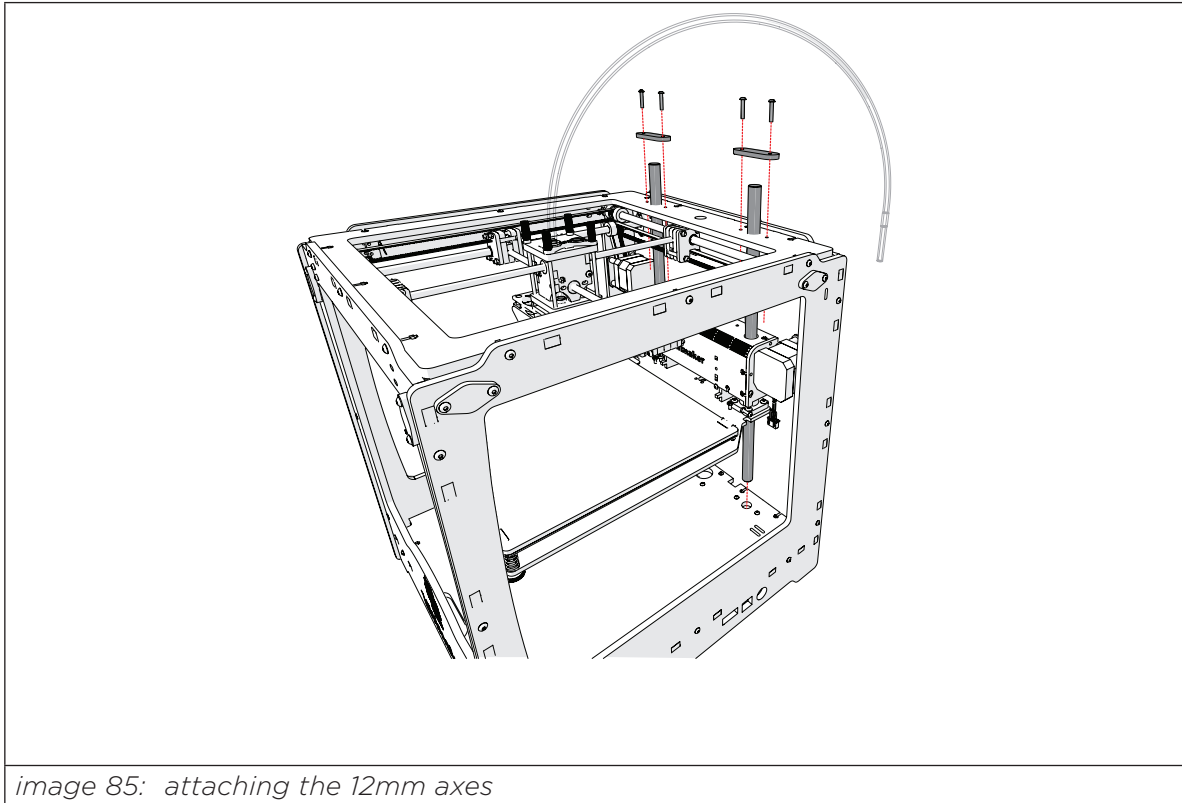

image 85: attaching the 12mm axes

6. Attach the Z-motor with the spindle by sliding it upwards into the frame. See image 86.
 - i** Notice: Make sure that the cable is facing away from the back plate.
7. Attach the motor to secure with 4x M3x10mm bolts it to the frame see image 86.



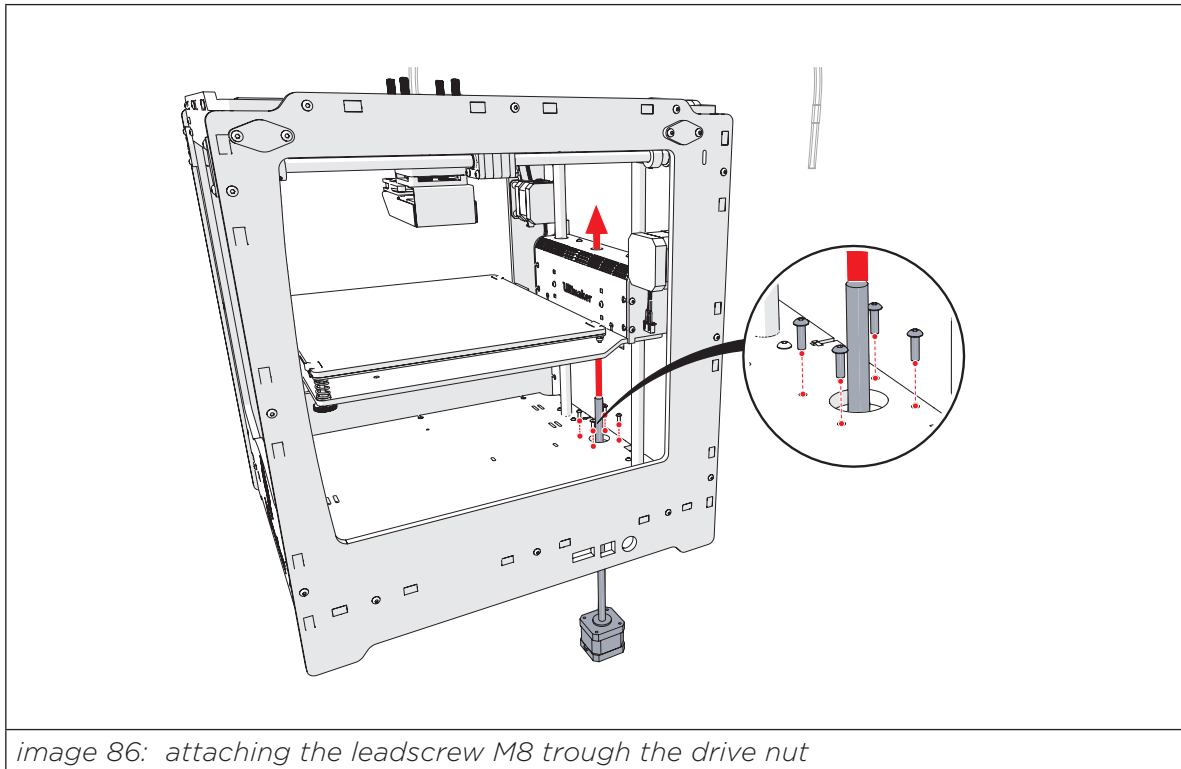

image 86: attaching the leadscrew M8 trough the drive nut

The frame is now ready!

6.4.6. Step 7: grease it up

The following parts are needed in this step.

Letter	Description	Qty.
	magnalube tube (1226)	1

To grease the leadscrew, perform the following actions.

1. Put a droplet of the supplied tube of grease on your finger (enough to slightly cover the entire axle).
2. Spread the droplet across the leadscrew (on straight line from top to down is fine).

i **Notice:** the drive nut will spread the grease later, when the leadscrew rotates.

i **Notice:** Do not use this grease to grease the x and y axis.

6.4.7. Step 8: Aligning the Z-stage

Letter	Description	Qty.
	M3x12mm bolt (1203)	2
	Hex nuts (1209)	2



To Align the Z-platform preform the following steps

1. Lift the wooden z-cap up. You can use the blue tape to tape it to the top of the machine.
2. Take the 2,5 Hex key and tighten one of the 8 bolts on the bearing.
3. Now grab the heated bed in the back where the spring is positioned and move it all the way up and down. This is so the bearing can align itself
4. Now repeat steps 2 and 3 for each of the 8 bolts on the bearings, alternating between the left and right bearing
5. If the Bed is aligned correctly. it should move up and down without much effort.

i Notice: Move the bed all the way up and down between tightning each bolt.

6. Slide 2 Hex nuts in the bottom two T-slots and use 2x M3x12mm inserted through the aluminium plate to screw them into place. see image 86a.
7. Now feed the heated bed cable through the cableduct in the back left corner of the machine. Make sure there is enough cable length to move the bed completely up and down.

i Notice: If the Z-stage Cap tilts forward when tightning down the nuts. Take some sanding paper and square off the bottem edge of the 6mm main wooden part.

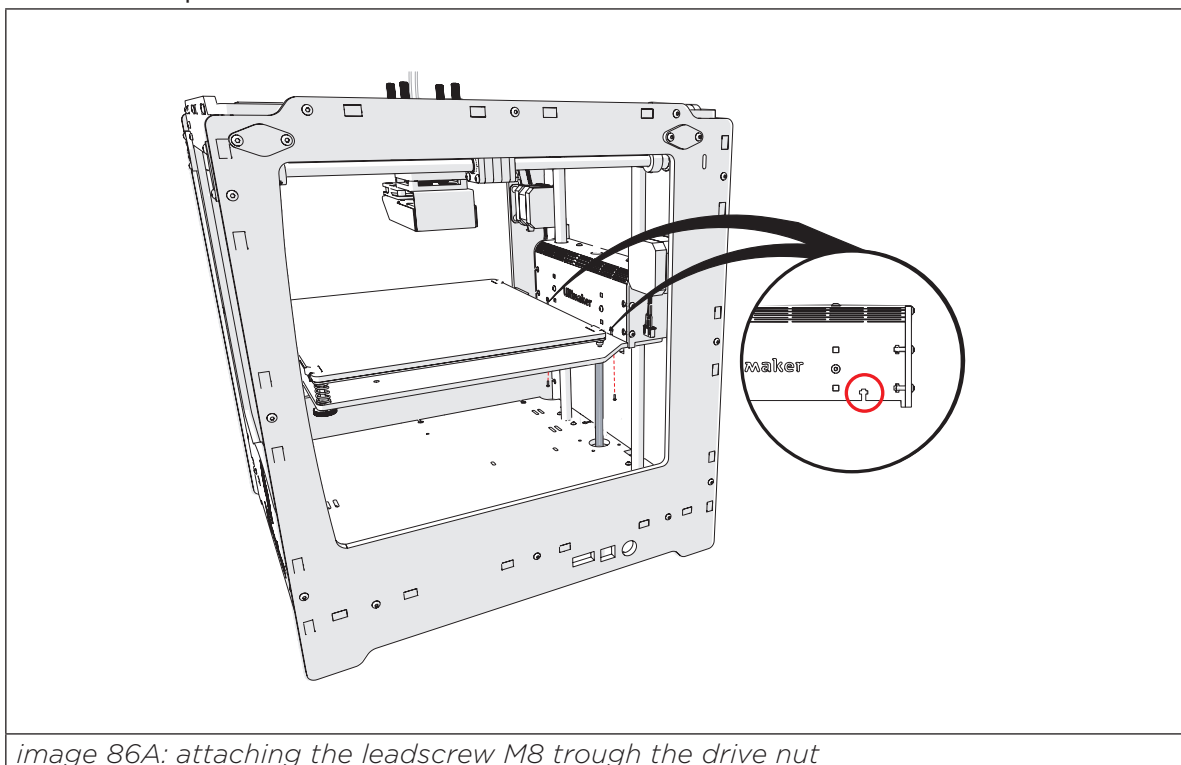

image 86A: attaching the leadscrew M8 trough the drive nut



ASSEMBLING THE MATERIAL FEEDER

WHAT YOU'LL NEED TO
ASSEMBLE THE MATERIAL
FEEDER.

Time:

about 30 to 40 minutes.

Tools:

hex keys (2mm)

adjustable wrench (has to fit M8nuts or pliers)

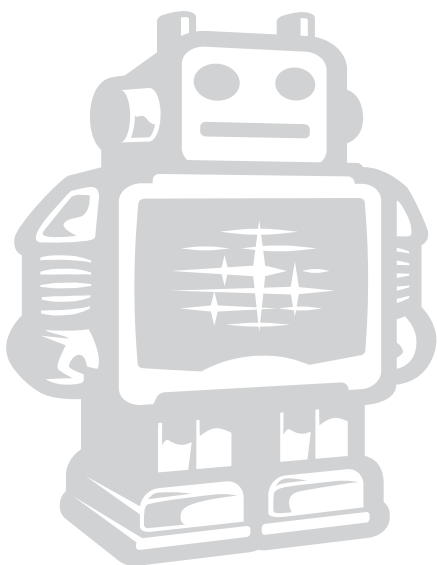

6.4.7. Step 1: drive mechanism main body assembly

The following parts are needed in this step.

Letter	Description	Qty.	Letter	Description	Qty.
A	wooden part 10A (1018)	1	G	stepper motor (with D profile) (1017)	1
B	wooden part 10B (1126)	1	H	Lock nuts 3mm (1214)	2
C	wooden part 10C (1528)	1	I	bolts M3 x 20mm (1206)	4
D	wooden part 10D (1509)	1	J	bolts M3 x 25mm (1207)	3
E	small black gear (1041)	1	K	ball bearings 8mm (1021)	2
F	quick fit coupling (1016)	1			

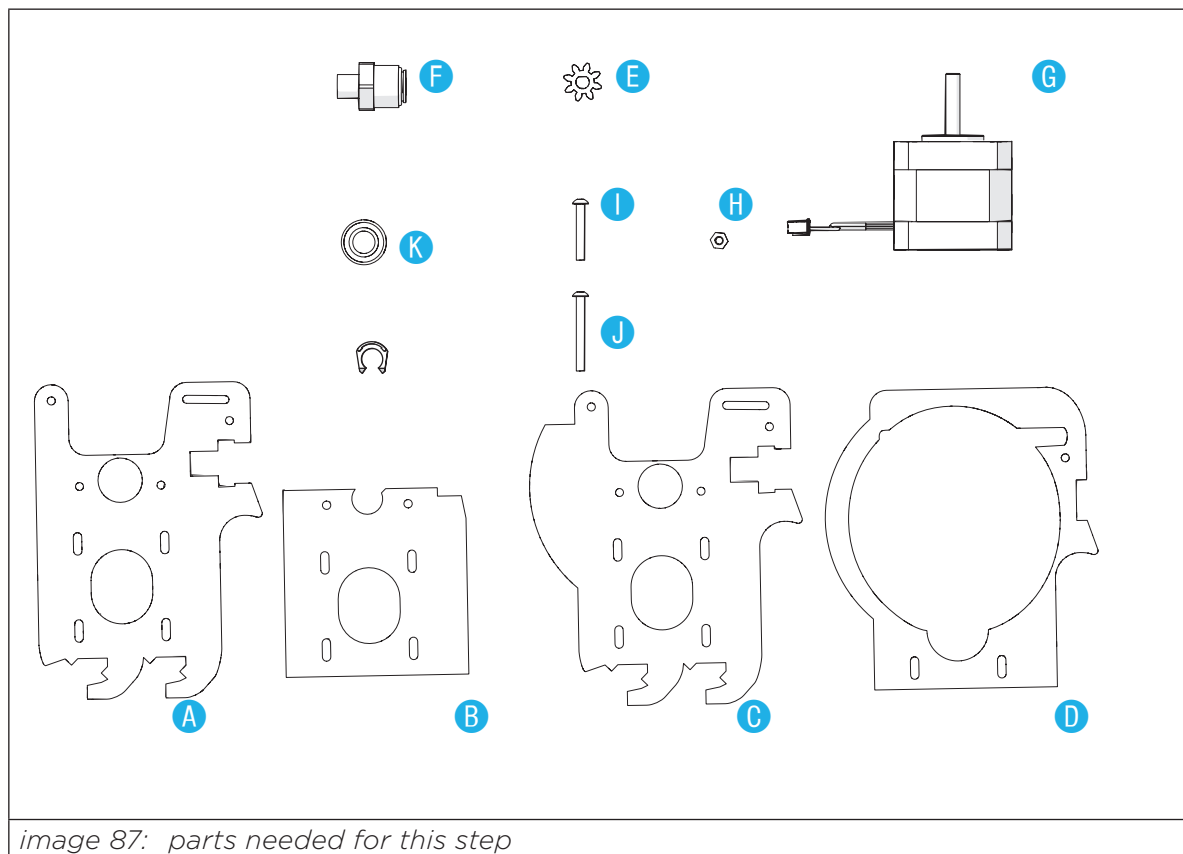

To assemble the extrusion head housing, perform the following actions.

1. Move the small black gear over the motor axis, see image 88.
- i** **Notice:** make sure the small black gear is placed on the top motor axis, so the motor axis does not stick out. This might need some force because it's a very tight fit.
2. Place a ball bearing 8mm in the hole of the wooden part 10A.
3. Place a ball bearing 8mm in the hole of the wooden part 10C, see image 89.



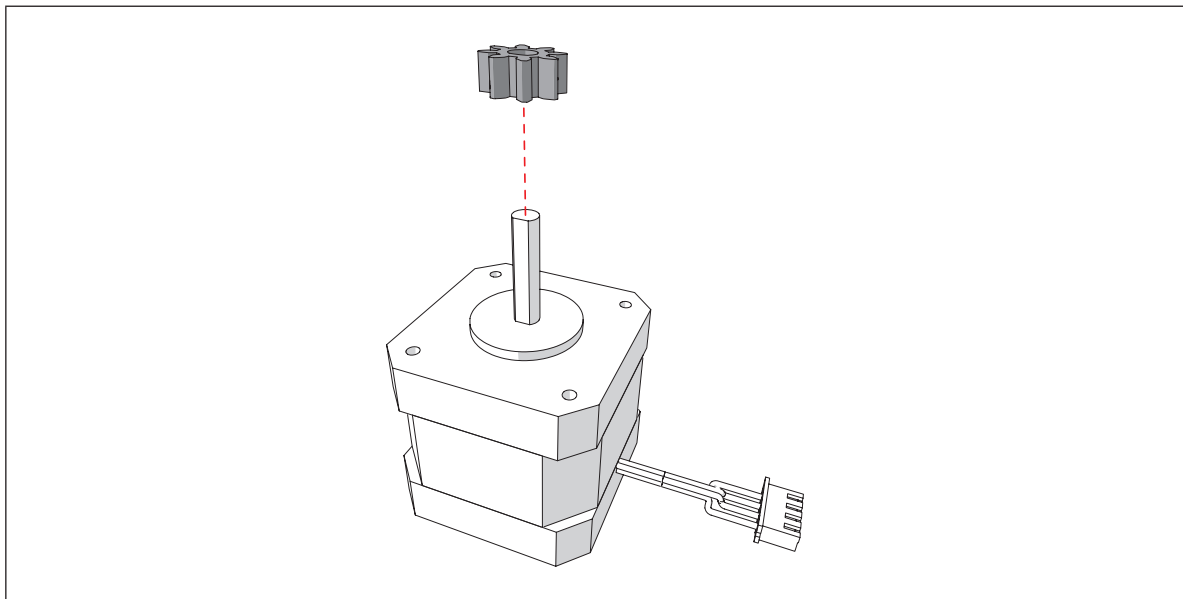

image 88: moving the small black gear over the motor axis

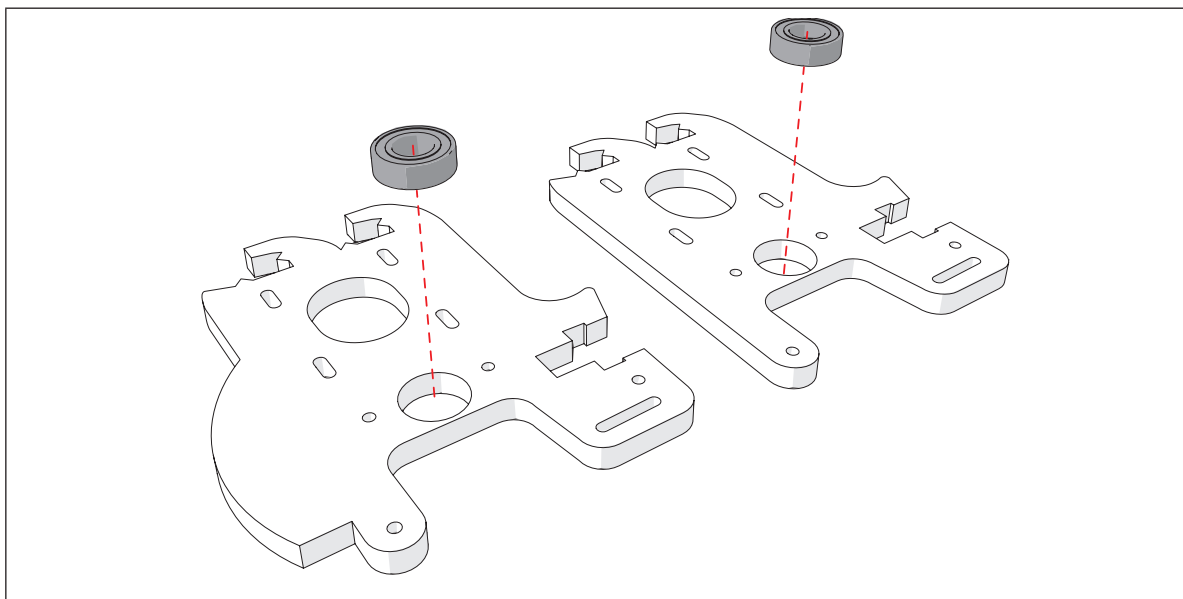

image 89: placing the ball bearings 8mm in the wooden part 10A and the wooden part 10C

(for action 4-9 see image 90)

4. Place wooden part 10A on top of the motor.
- i** **Notice:** make sure the engraving is facing the motor.
5. Place the wooden part 10B on top of the wooden part 10A.
6. Place the quick fit coupling in the T-slot.
7. Place the wooden part 10C on top of the wooden part 10B.
8. Place the wooden part 10D on top of the wooden part 10C.
9. Attach the wooden parts A, B, C and D on the motor.



Use two bolts M3 x 20mm and two bolts M3x25mm. the M3x20mm sit inside the plate 10D.

10. Use one M3x 25mm bolt and one Locknut to secure the hole in the top corner.
11. Place two bolts M3 x 20mm near the ball bearings and one near the top corner then lock them with two lock nuts.

i **Notice:** Do not tightend the Bolts securing the motor to much this makes it easier later on.

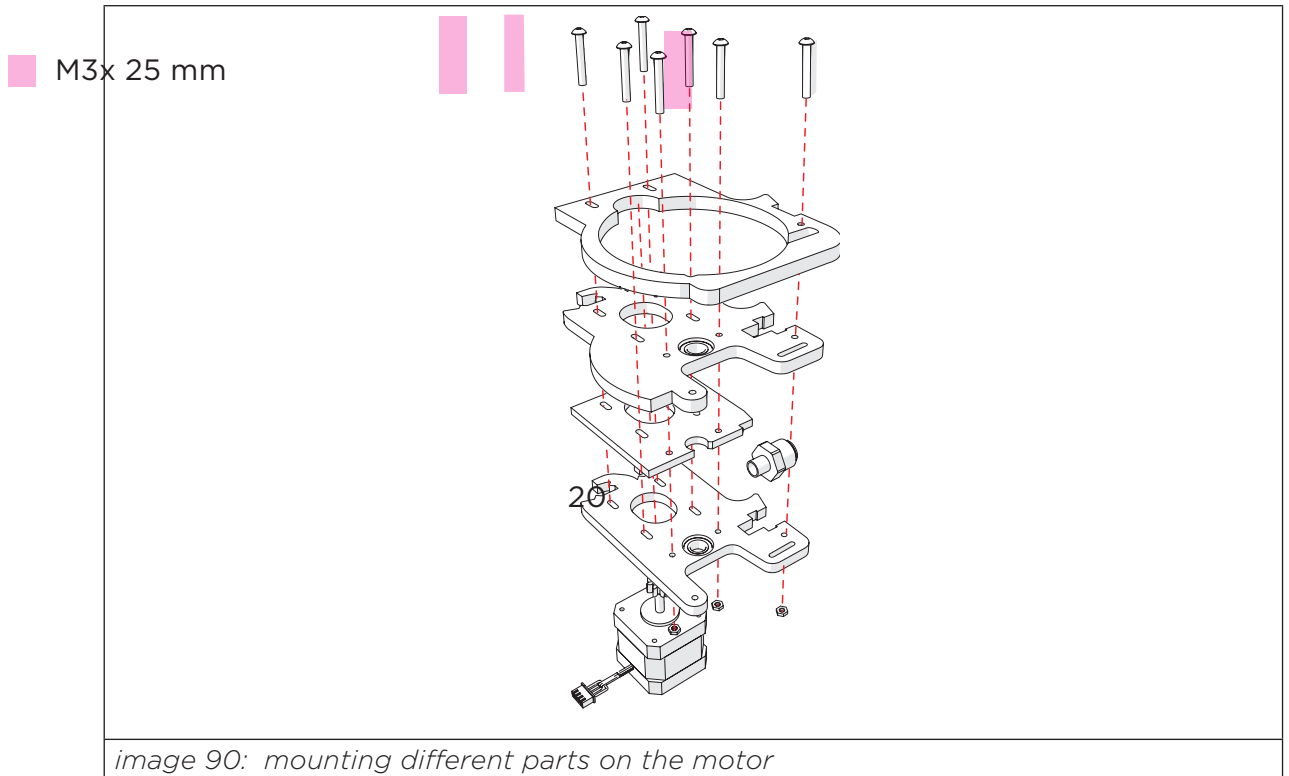

6.4.8. Step 2: drive bolt assembly

The following parts are needed in this step.

Letter	Description	Qty.	Letter	Description	Qty.
A	wooden gear (engraved extrude) (1128)	1	F	washers M8 (1136)	2
B	wooden gear Cap (1510)	1	G	hex nut M8 (1137)	1
C	delrin clip (1031)	1	H	hobbed bolt (1133)	1
D	Locknut (1214)	3	I	cap nut M8 (1134)	1
E	M3x14mm (1205)	3			



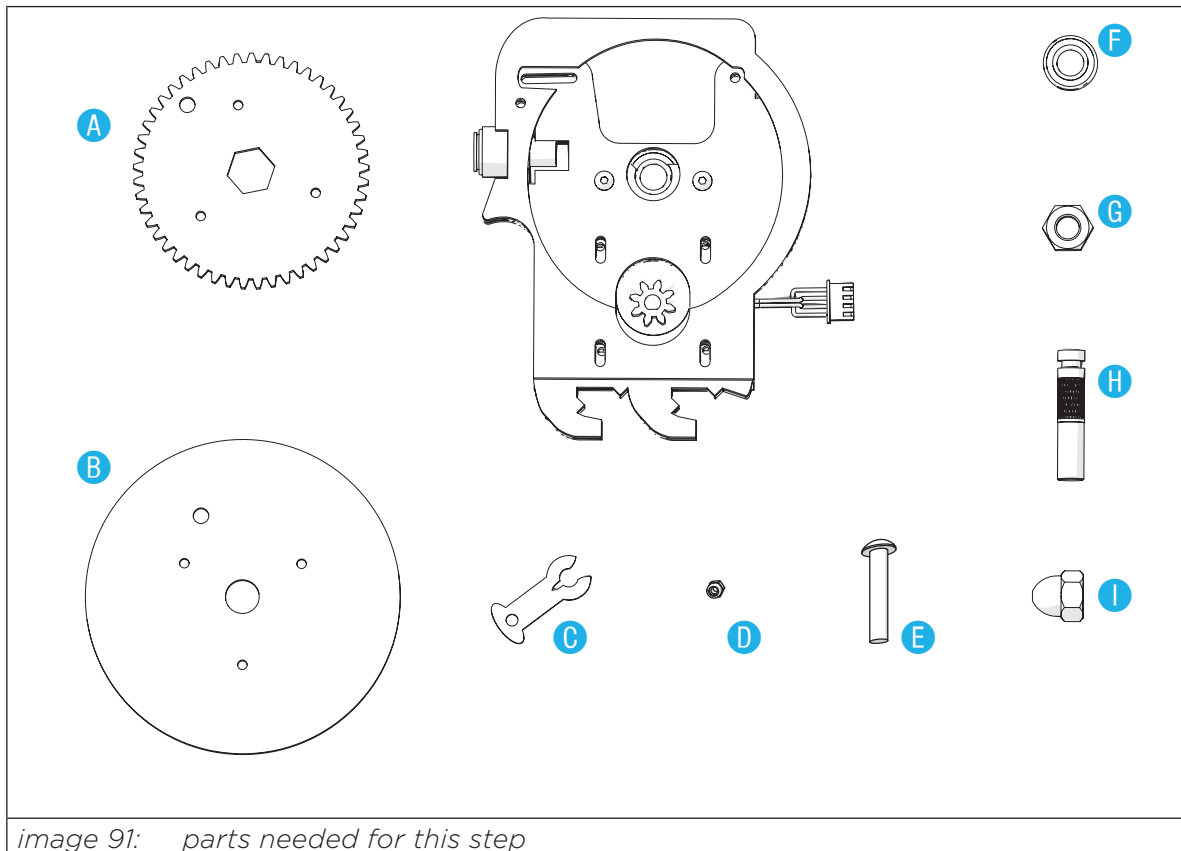

image 91: parts needed for this step

To make the drive bolt assembly, perform the following actions.

(for action 1-9 see image 92)

1. Place the hex nut M8 inside the wooden gear and make sure its lined up straight.
 2. Place the Wooden gear cap over the wooden gear, make sure to line up the 4 holes and the engraving is on the outside.
 3. Bolt them together with 3x M3x14mm bolts and 3x Locknuts. Make sure the locknuts are on the engraved side of the wooden gear cap.
 4. Attach the wooden gear on the hobbed bolt
 5. Place two washers M8 over the hobbed bolt.
 6. Move the hobbed bolt through the ball bearings.
- i Notice:** check if the 'good' gripping part of the drive bolt is positioned straight between the two wooden parts. If not, consider to attach the wooden parts of the drive mechanism main body a little more tight.
- i Notice:** Do not attach too tight. Check if the gear can rotate freely in the ball bearings 8mm.
- i Notice:** make sure the small black gear and wooden gear are not under pressure.
7. Place the delrin clip on the groove of the hobbed bolt.
 8. Place the cap nut M8 loosely on the hobbed bolt.
 9. Now carefully tighten the cap nut M8 and the wooden gear. Be sure the hobbed bolt is able to rotate in the ball bearings 8mm.
- i Notice:** do not force!



10. Check if the motor with the small black gear makes contact with the wooden gear. Adjust if necessary. Use the hole in the Drive wheel to adjust the screws

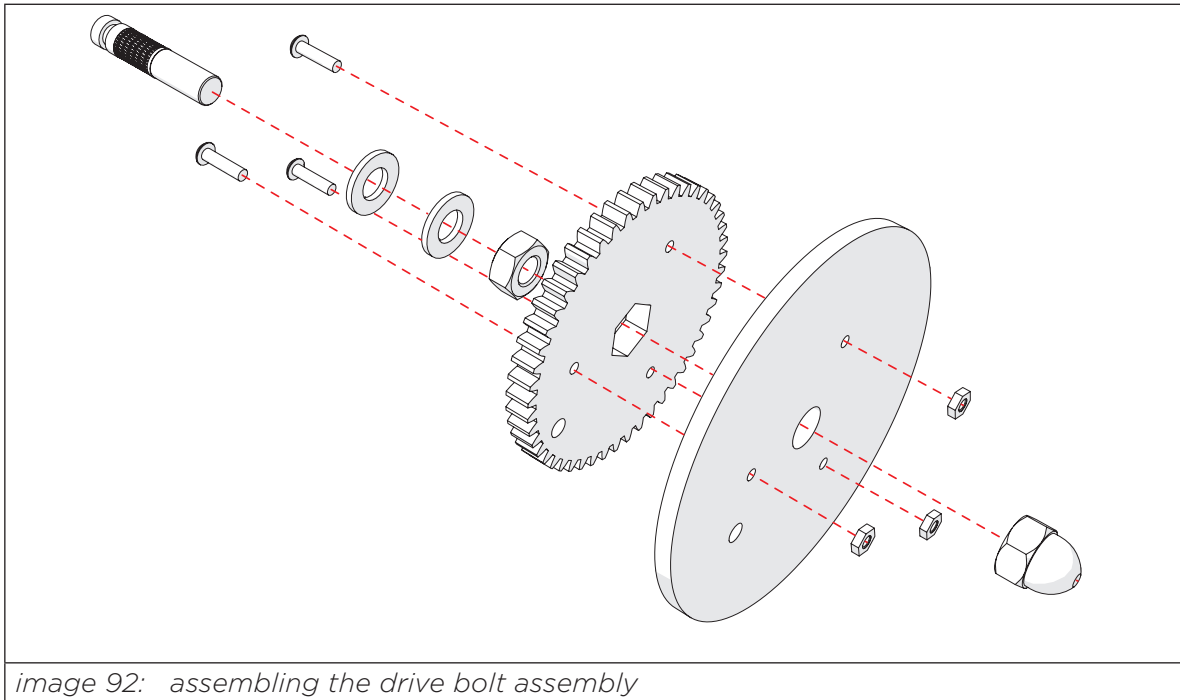

6.4.9. Step 3: clamp assembly

The following parts are needed in this step.

Letter	Description	Qty.	Letter	Description	Qty.
A	U-Bracket (1039)	1	H	bolts M3 x 20mm (1206)	3
B	black wheel (1036)	1	I	spring (1143)	1
C	mounting plate (1034)	1	J	hex nut 3mm (1209)	1
D	bolts M3 x 16mm (1204)	4	K	side plate B (1034)	1
E	washer (1201)	1	L	bolts M3 x 25mm (1207)	1
F	Small ball bearing (1142)	1	M	lock nuts (1214)	7
G	side plate A (1032)	1	O	Black Lever (1035)	1



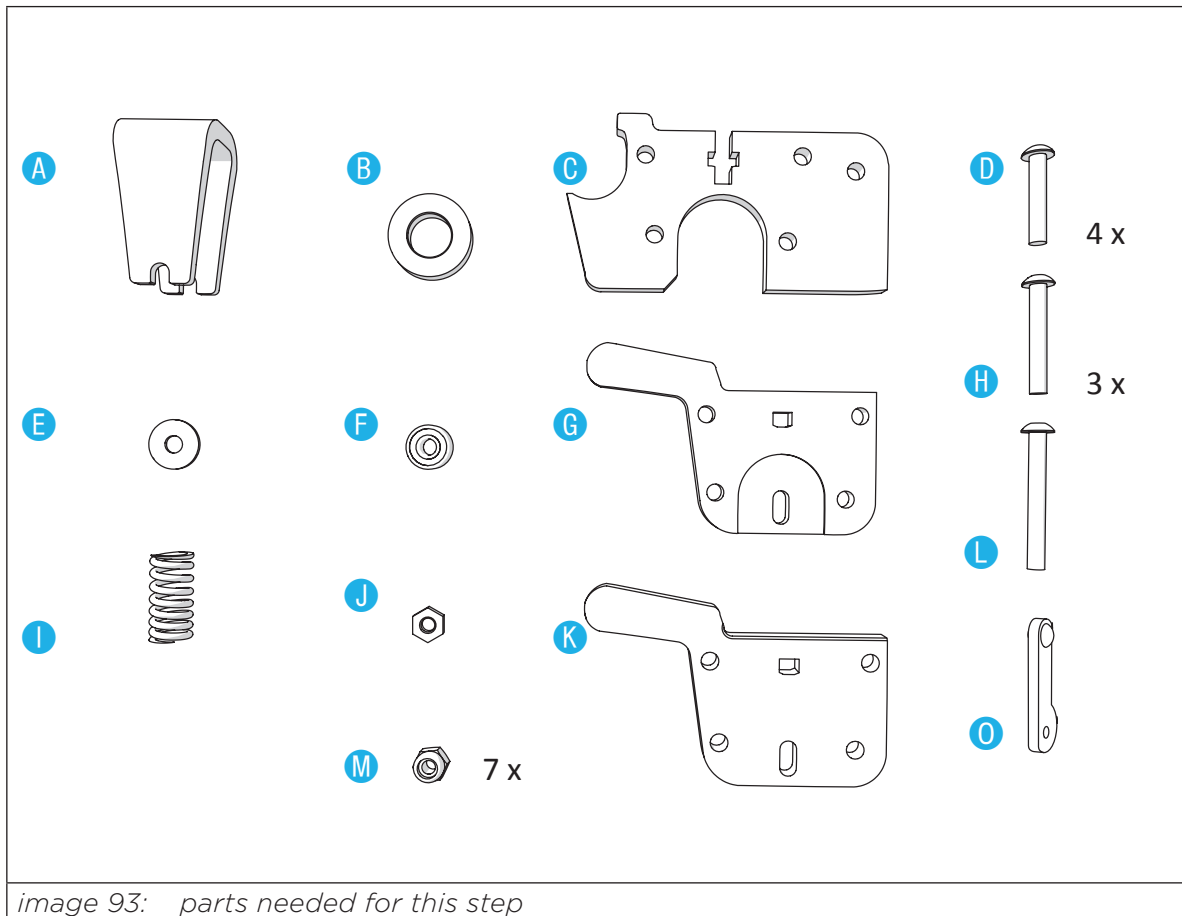

image 93: parts needed for this step

To make the clamp assembly, perform the following actions.

1. Push the small ball bearing in the black wheel, see image 94.
Tip: use a piece of redundant wood to apply more force if needed.
2. Place a hex nut 3mm in the T-slot of the mounting plate, see image 95.
(for action 3-5 see image 96)
3. Use four bolts M3 x 16mm through side plate B and put it on its side with the cut-away facing upwards.
4. place the mounting plate on top of it. Then the side plate A on top and tighten down with 4 lock nuts.
5. Place the black wheel (with small ball bearing) in the mounting plate..
i **NOTICE:** mind the orientation.
6. Place ONE bolt M3 x 20mm through the small ball bearing and place the nut just on the top of the screw.
Use ONE lock nut.



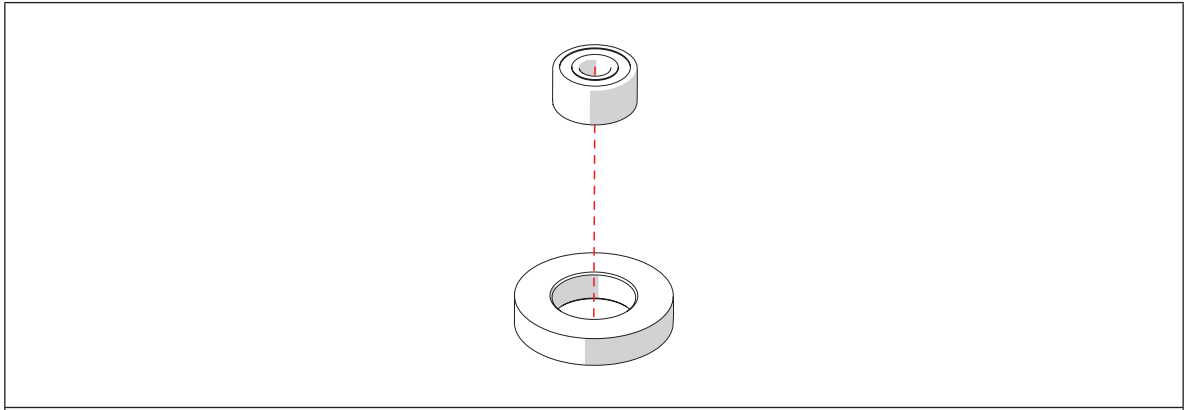

image 94: pushing the small ball bearing in the black wheel

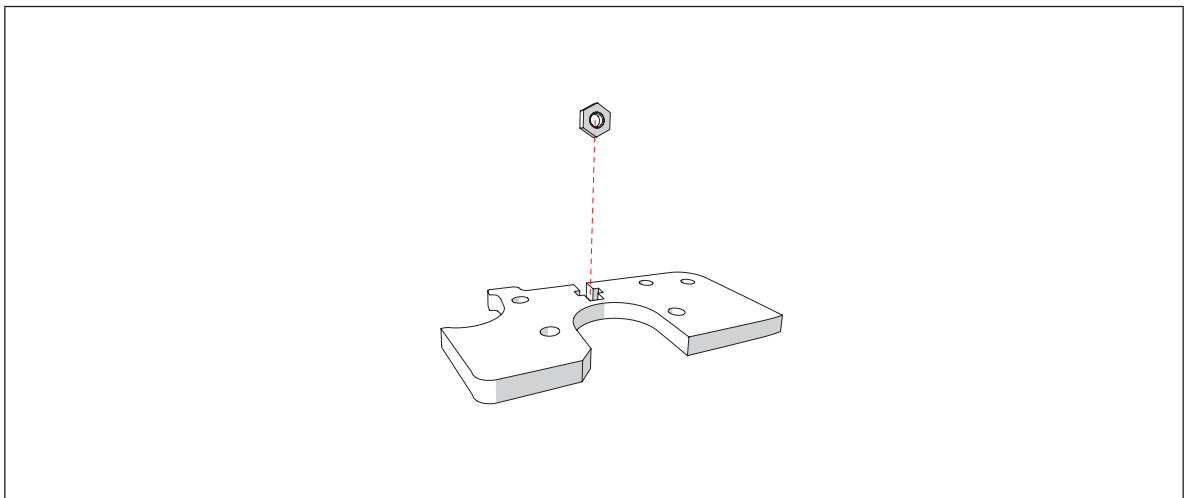

image 95: placing a hex nut 3mm in the mounting plate

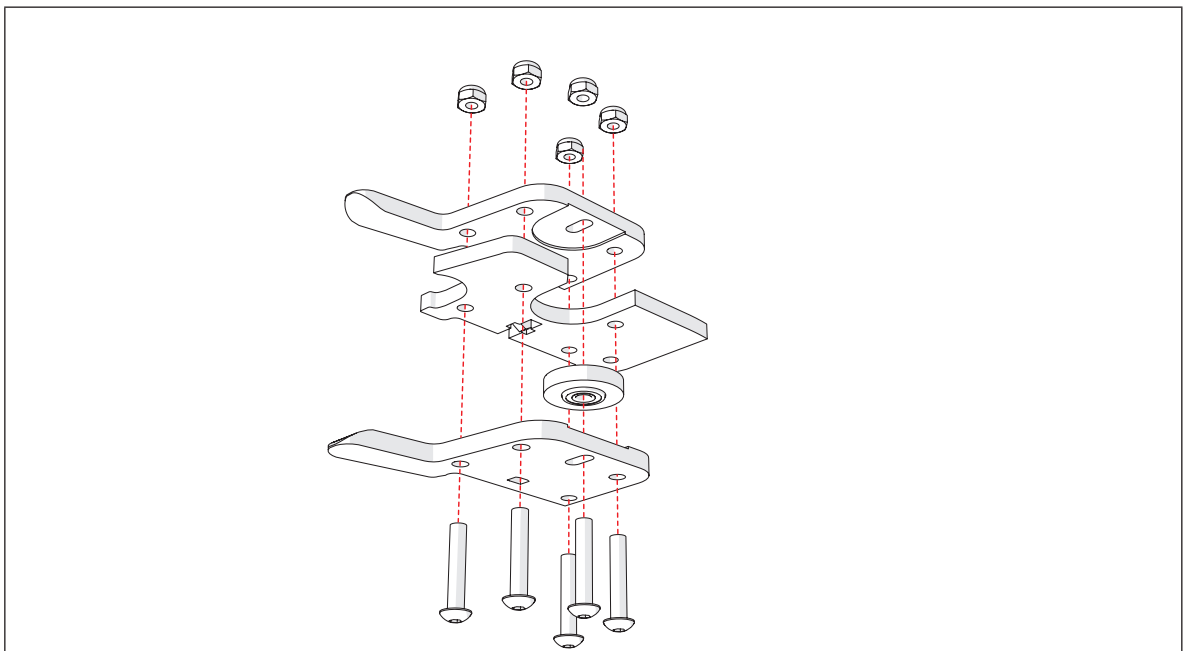

image 96: placing the side plates over de mounting plate



7. Place the U-Bracket on side of the clamp assembly, see image 97.
8. Attach a spring and a washer on the hole of the U-Bracket.
Use a bolt M3 x 25mm.

- i** **Notice:** because you have to push the spring, it can take some force.
- i** **Notice:** the spring should stick out about 11mm.

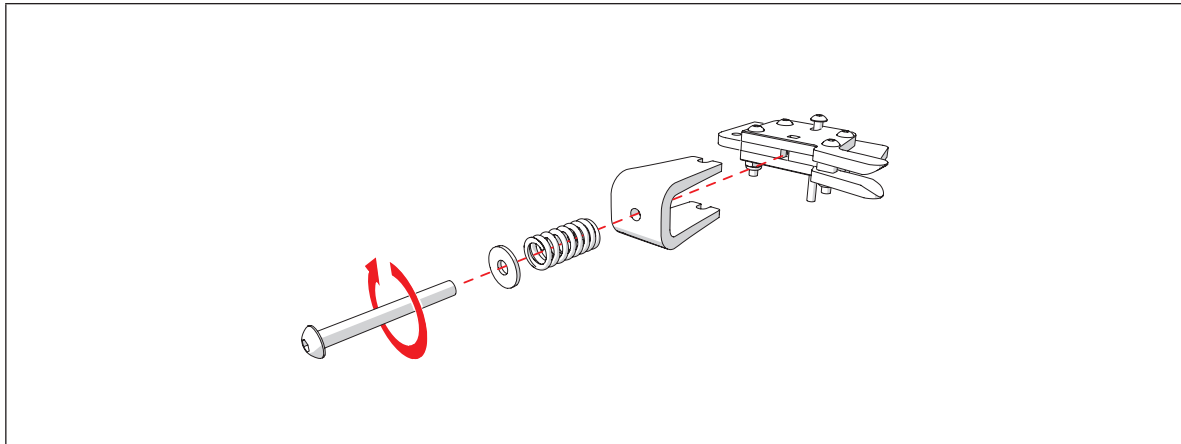

image 97: placing the U-Bracket on the clamp assembly

The result must look like this, see image 98.

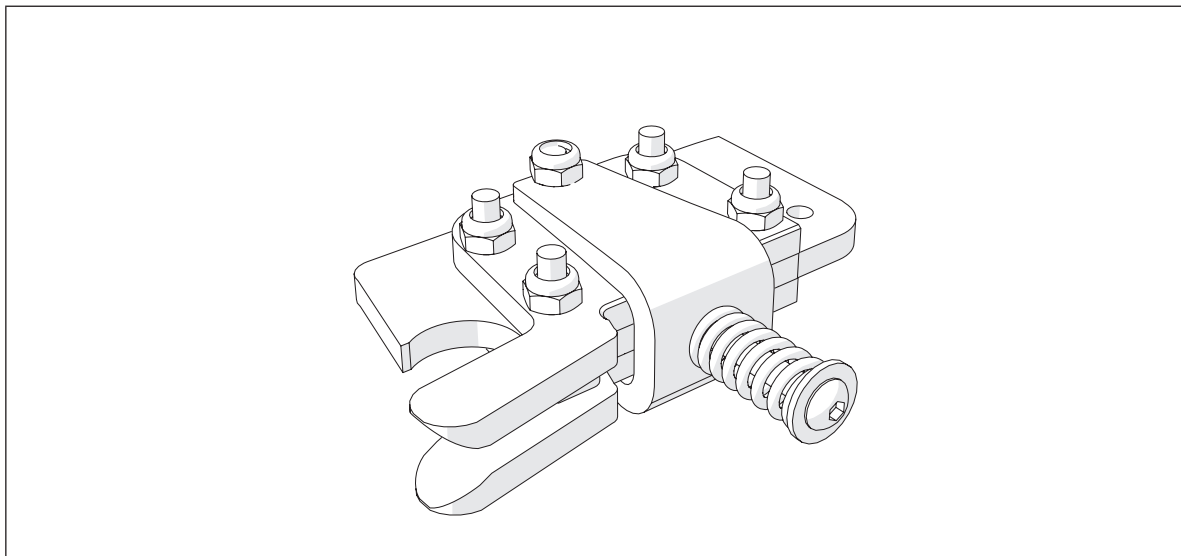

image 98: result after attaching the U-Bracket on the clamp assembly

(for action 8-9 see image 99)

9. Attach the clamp assembly with U-Bracket on the main body of the drive mechanism.
Use ONE bolt M3 x 20mm and ONE lock nut.
 - i** **Notice:** do not screw too tight, the clamp assembly with U-Bracket must be able to move.
 - i** **Notice:** make sure the lock nut is NOT placed on the side of the gear.
10. Connect the lever to the main body of the drive mechanism.



Use ONE bolt M3 x 20mm and a ONE lock nut.

i **Notice:** do not screw too tight, it must be able to move.

i **Notice:** make sure the lock nut is NOT placed on the side of the gear.

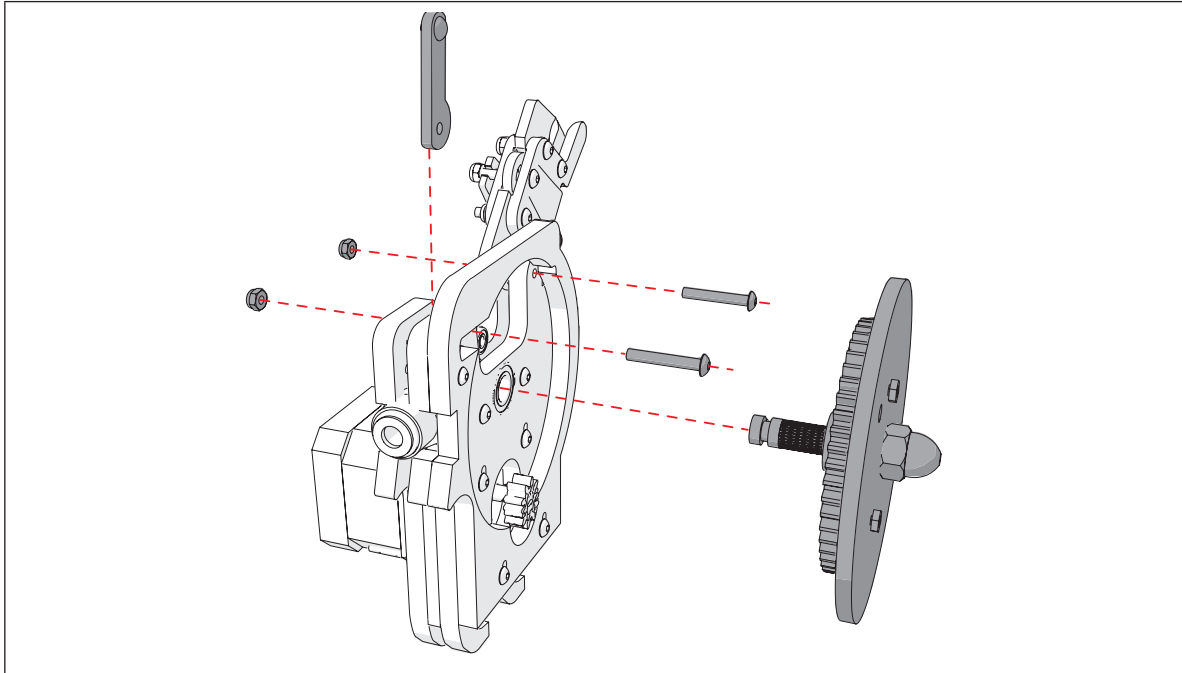

image 99: attaching the clamp assembly with U-Bracket and the lever on the main body of the drive mechanism

The result must look like this, see image 100.

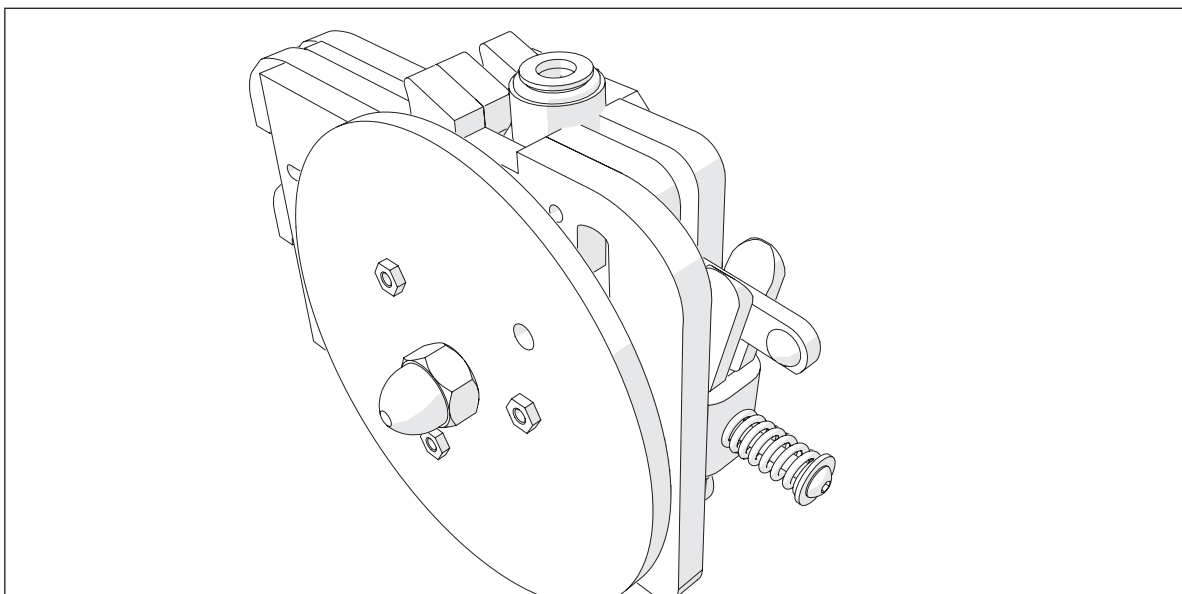

image 100: result after attaching the clamp assembly with U-Bracket and lever on the main body of the drive mechanism



6.4.10. Step 4: attaching the feeder to the machine

Letter	Description	Qty.
	blue horse shoe (1071)	1

To attach the feeder to the machine, perform the following actions:

1. Attach the Material feeder in the slots of the BACK panel, see image 101
2. Place the bowden tube in the tube coupling of the material feeder mechanism.
3. Press down on the bowdentube and secure it with a blue horse shoe.
4. Move the wires from the material feeder through the hole below the material feeder of the BACK panel and through the cableduct.
5. Move the wires through the corner hole of the BOTTOM panel.

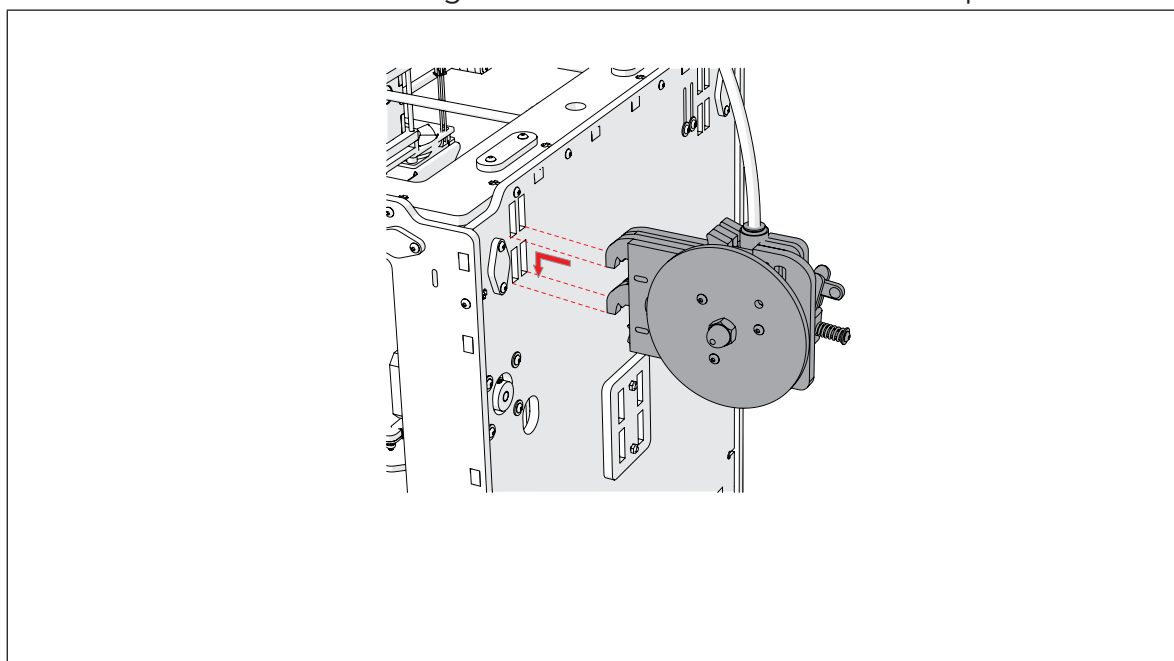

image 101: attaching the clamp assembly with U-Bracket and lever on the main body of the drive mechanism

6.4.11. Step 5: assemble the filament holder

The following parts are needed in this step.

Letter	Description	Qty.	Letter	Description	Qty.
A	wooden parts 11B (1008)	2	B	wooden parts 11C (1511)	6
C	Small wooden part 11B (1116)	2			



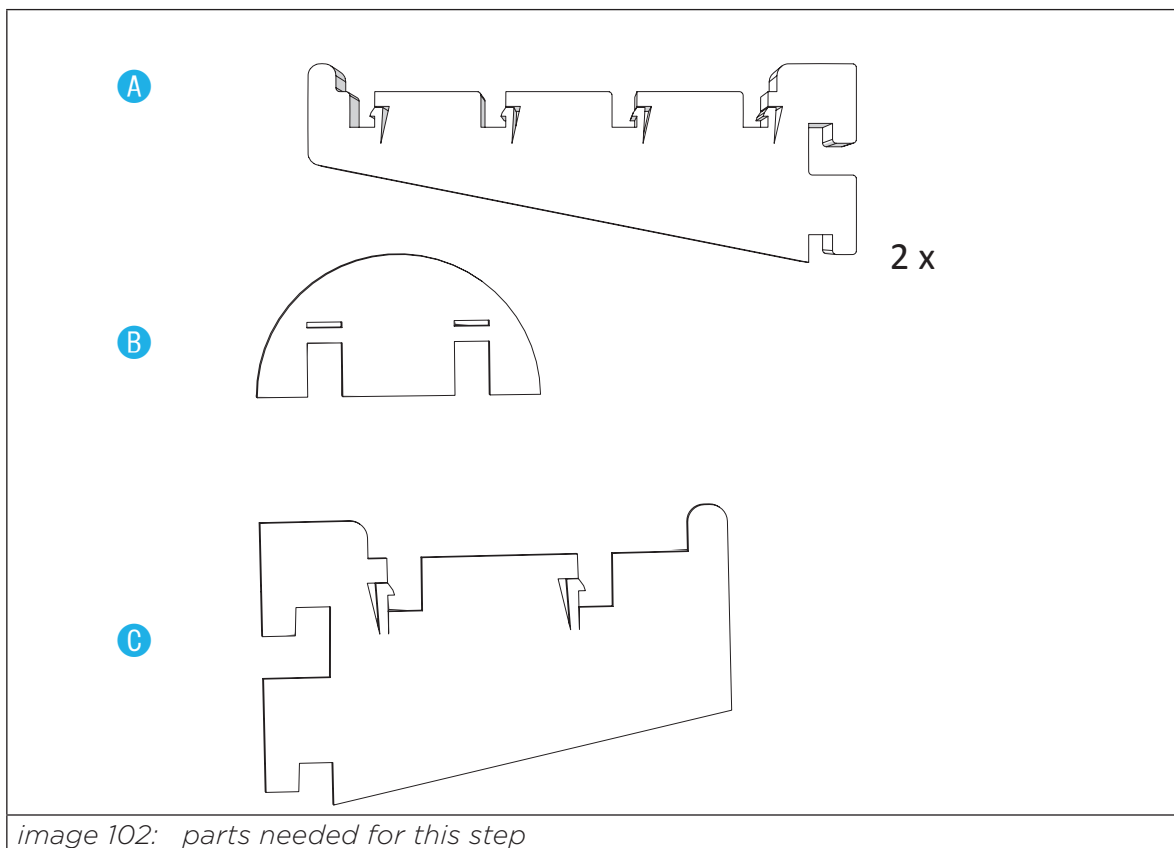

To assemble the filament holder, perform the following actions.

1. Position two wooden parts 11B and 11D next to each other.
2. Push the four wooden parts 11C in the slots of the two wooden parts 11B and 11D, see image 103.

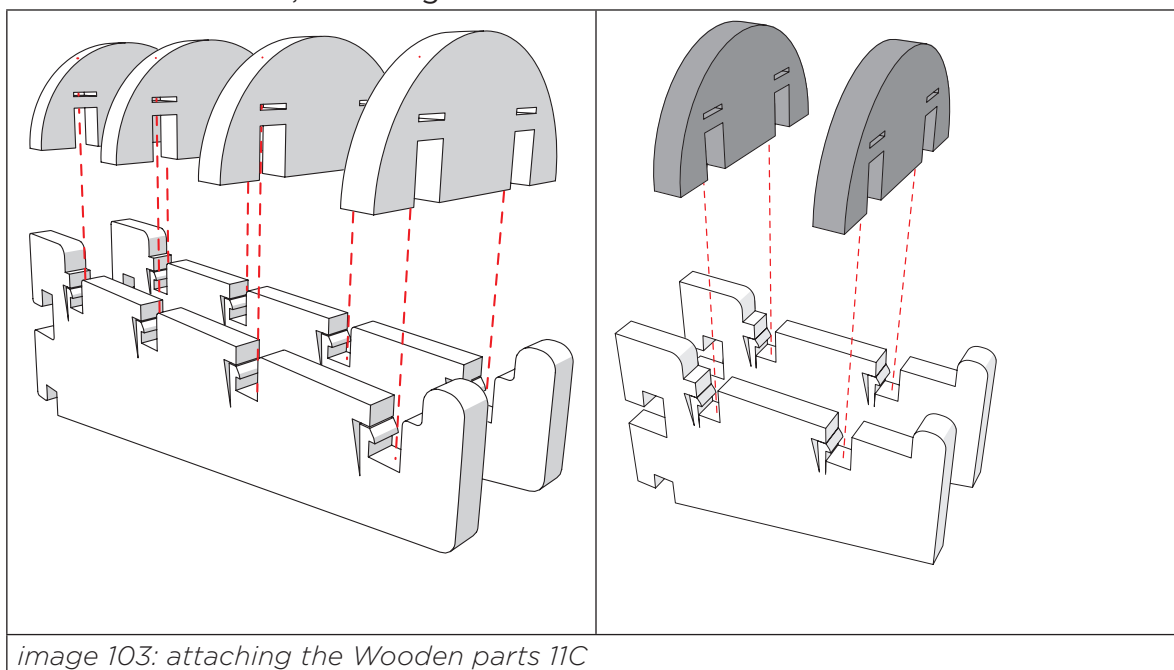

3. Place the filament holder in the slots in the BACK panel, see image 104.

i **Notice:** There are 2 filament holders supplied, for one or two rolls.



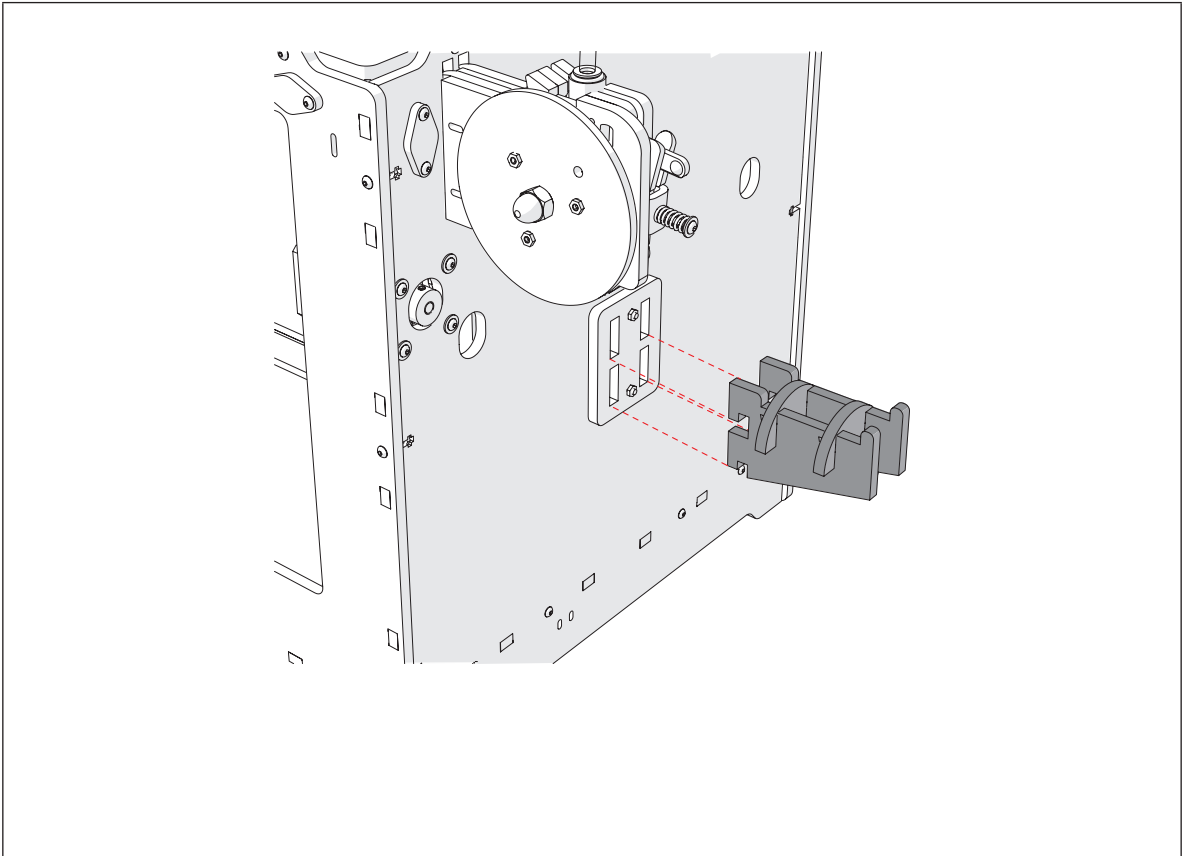

image 104: attaching the filament holder in the BACK panel



6.5

MOUNTING THE ELECTRONICS CIRCUIT BOARD

WHAT YOU'LL NEED TO MOUNT THE ELECTRONICS CIRCUIT BOARD.

Time:

about 30 to 60 minutes.

Tools:

hex keys (2mm)

tiny flat screwdriver

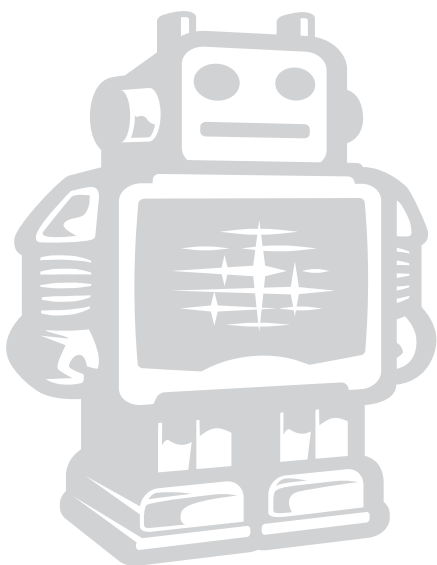

What you need to know before you start attaching the electronics.
 The electronics simply need to be attached to the machine and a few wire connectors plugged in.



Warning! When handling electronics make sure that you are not statically charged. This can permanently damage your electronics. Try touching bare metal from a radiator or anything else that would help.

6.5.1. Step 1: mounting the electronic circuit board

The following parts are needed in this step.

Letter	Description	Qty.	Letter	Description	Qty.
A	bolts M3 x 20mm (1206)	4	C	electronic circuit board (1091)	1
B	Spacer 8mm (1502)	4	D	Jumpers (1315)	2

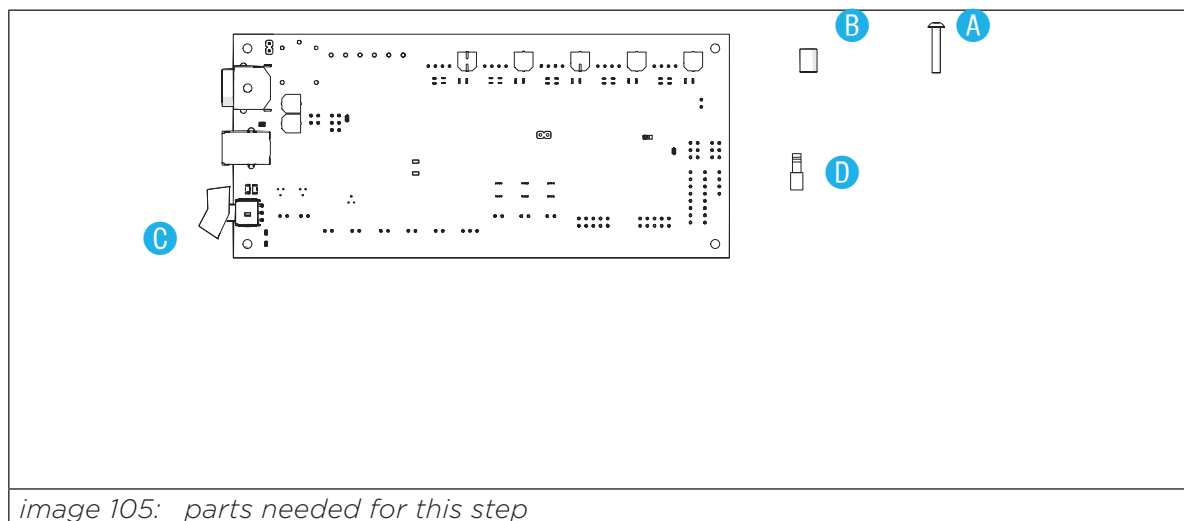

image 105: parts needed for this step

To attach the electronic circuit board, perform the following actions.

(for action 1-4 see image 106)

1. On the BOTTOM panel put four bolts M3 x 20mm from INSIDE towards OUTSIDE.
2. Place the tube spacers over the four bolts M3 x 20mm.
3. Place the electronic circuit board over the bolts M3 x 20mm, on the tube spacers.



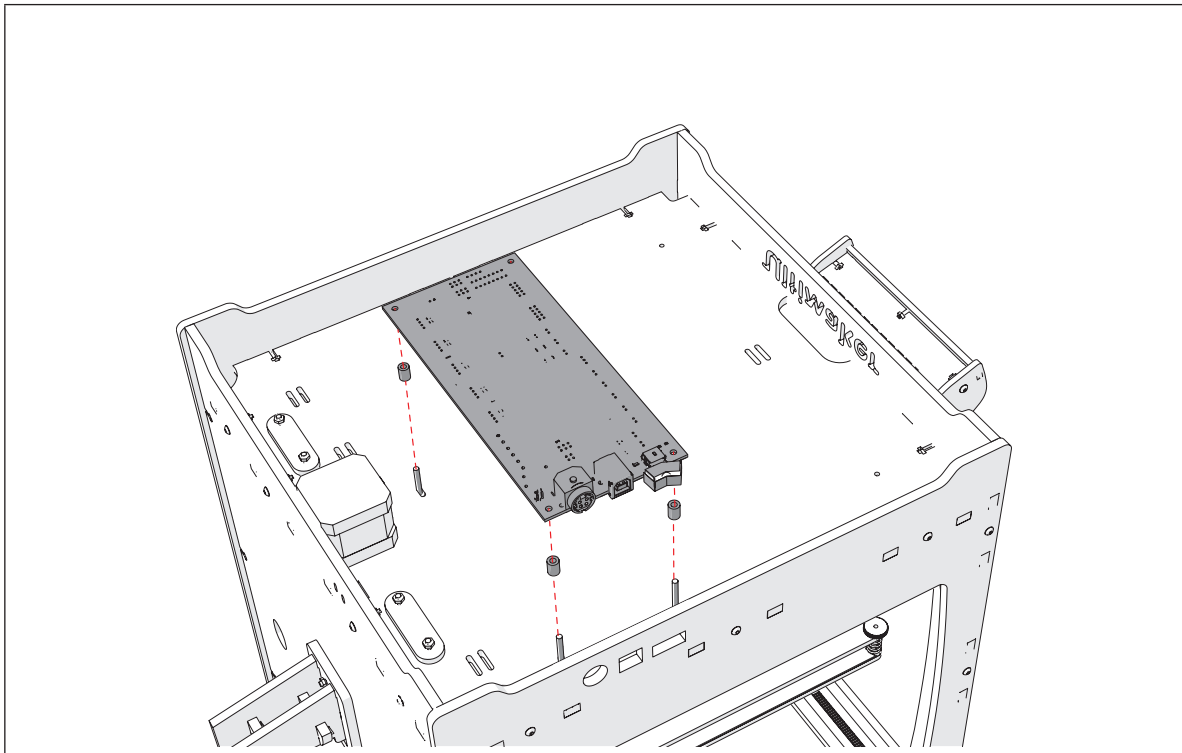

image 106: mounting the electronics circuit board

6.5.2. step 2: connecting the heater and Heated Bed

To connect the heater, perform the following actions.

i There is no +/- Wire for the heaters. Just make sure they are screwed in securely.

1. Connect the WHITE wires of the heater element to the terminals of the heater 1 output, see image 107.

i **Notice:** do not strip the wires too much. This can cause short circuit.

i **Notice:** do not strip the wires too short. This can cause no contact.

2. Attach the wires in the terminals.

Use a small screwdriver.

i **Notice:** make sure the cable is secure.

3. Connect the Gray wires of the heater element to the terminals of the heated bed output

4. Attach the wires in the terminals.

Use a small screwdriver.

i **Notice:** make sure the cable is secure.

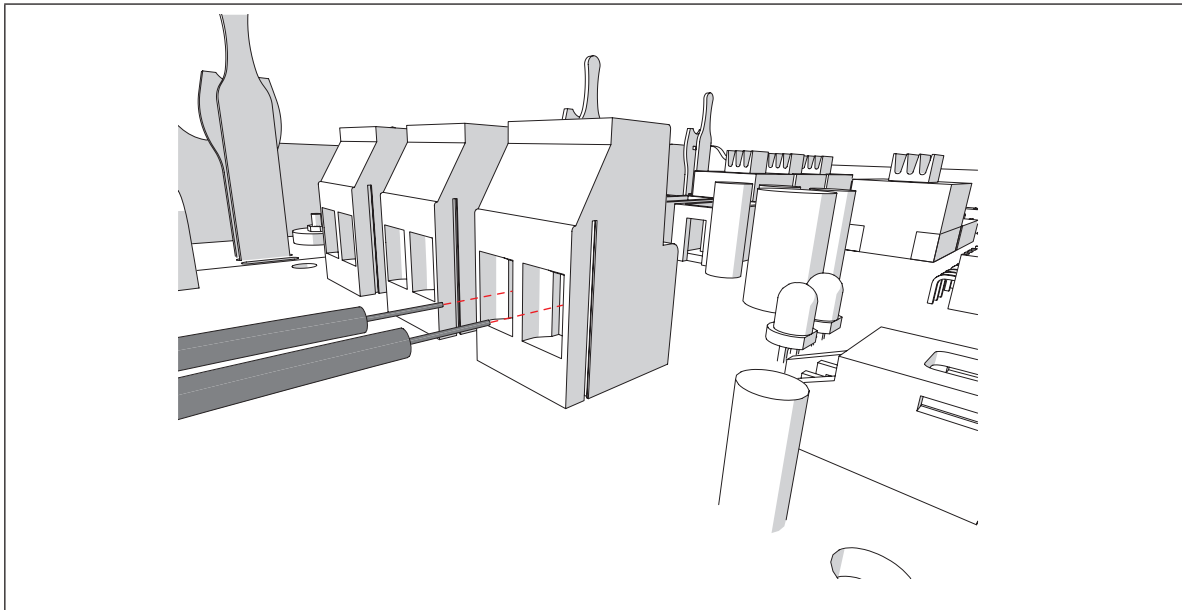

image 107: connecting the heater



6.5.3. Step 3: connecting the print head electronics

To connect the print head electronics, perform the following actions

1. Turn the machine on its side.
2. Plug in the Black/Red plug in the connector called FAN PWM on the circuit board.
3. Plug in the metallic sleeved PT100 plug in the connector called TEMP1 on the circuit board.
4. Plug in the RED Heated bed temp plug in the connector called TEMP3 on the circuit board.

i Some wires need to fit underneath the the housing and the electronics board.

6.5.4. Step 4: connecting the limit switches

To connect the limit switches, perform the following actions.

1. Connect the plug of BLACK wired limit switch to the connector Z-end stop on the circuit board.
The BLACK wired limit switch is situated at the TOP of the machine.
2. Connect the plug of RED wired limit switch to the connector Y-end stop on the circuit board.
The RED wired limit switch is situated at the LEFT of the machine.
3. Connect the plug of BLUE wired limit switch to the connector X-end stop on the circuit board.
This BLUE wired limit switch situated at the FRONT of the machine.
4. Take the black jumpers and place them on the connectors marked Saftey 1 and 2.

6.5.5. Step 5: connecting the motors

To connect the motors, perform the following actions:

1. Connect the plug of X motor to the connector called X motor on the circuit board.
The X motor is mounted on the BACK plane inside the machine.
2. Connect the plug of Y motor to the connector called Y motor on the circuit board.
The Y motor is mounted on the LEFT panel inside the machine.
3. Connect the plug of Z motor to the connector called Z motor on the circuit board.
The Z motor is mounted on BOTTOM panel under the machine.
4. Connect the plug of EXTRUDER-MOTOR to the connector called E1 on the circuit board.
The EXTRUDER-MOTOR is mounted on the EXTRUDER outside the machine

i **Notice:** check the connections you have just made.



6.5.6. Step 6: mounting the electronics cover

The following parts are needed in this step.

Ltr.	Description	Qty.
A	Electronics Cover (1529)	1
B	8mm Spacer (1502)	4
C	M3x20mm Bolt (1206)	4

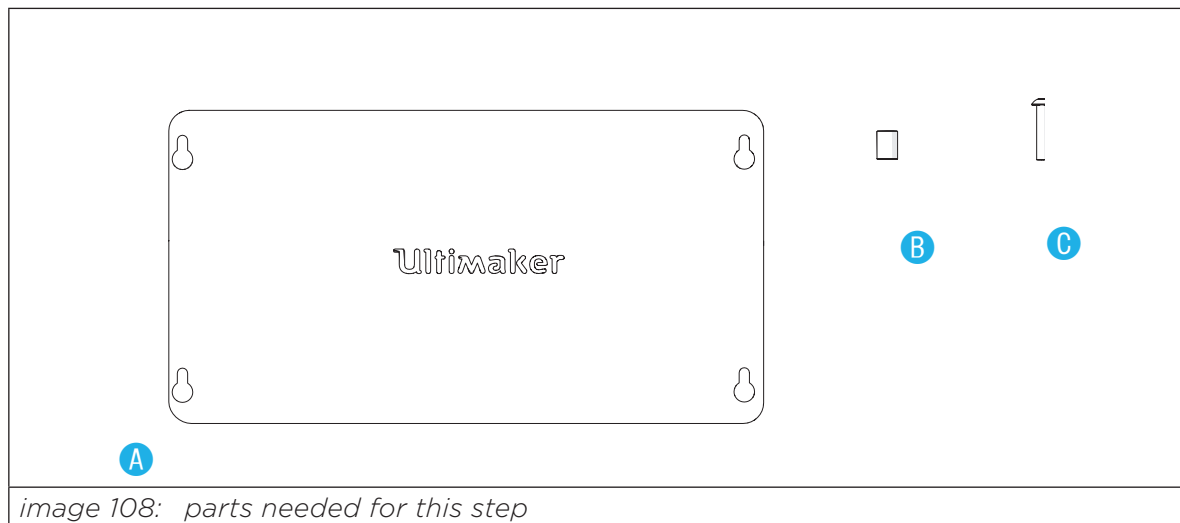

To mount the electronic cover system, perform the following actions.

(for action 1-4 see image 108)

1. Attach the bolts M3x20mm with the spacers into the Electronic's threaded spacers, but not all the way
2. Place the electronics cover over the bolts M3 x 20mm.
3. Shift the electronics cover.
4. Attach the bolts M3 x 20mm slightly more, till they touch the wood.



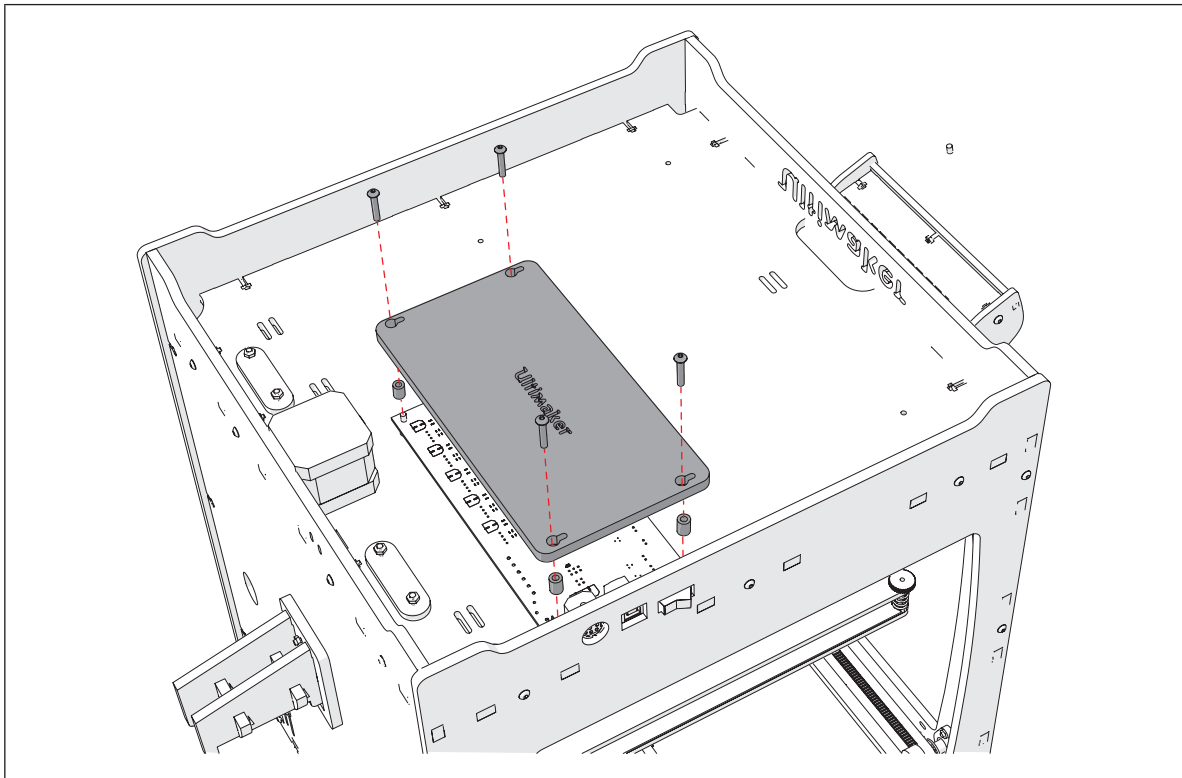

image 109: mounting the electronic cover

6.5.7. Step 7: strain relief

To achieve strain reliefs, perform the following actions.

1. Wrap the black cable, bow shaped tube, and the white cables (all connected with to the extrusion head) together in transparent wire wrapping.

i **Notice:** Goal is to get a tidy cable. When to long cut the last bit of the wrapping.

2. Wrap all cables together at the underside of the BOTTOM plate. Use the velcro strips.



6.6 ASSEMBLING AND CONNECTING THE ULTICONTROLLER

WHAT YOU'LL NEED TO ASSEMBLE AND CONNECT THE ULTICONTROLLER.

Time:

about 10 to 20 minutes.

Tools:

hex keys (2mm)

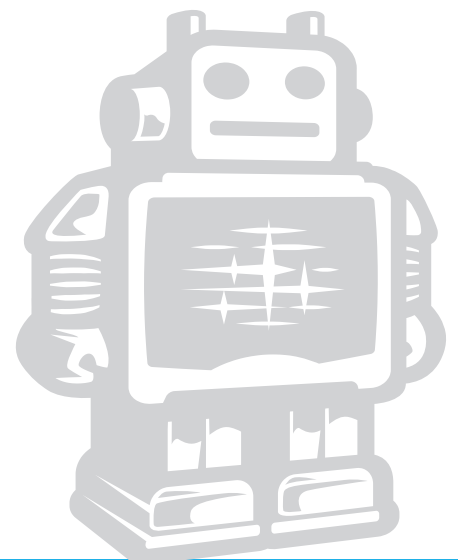

6.6.1. Step 1: assembling the UltiController

The following parts are needed in this step.

Letter	Qty.	Description	Letter	Qty.	Description
A	1	UltiController BACK (1093)	G	1	UltiController LEFT (1092)
B	1	display v1.0 (1146)	H	1	UltiController RIGHT (1089)
C	4	white tube spacer 15mm (1139)	I	4	Nylon bolts M3 x 25mm (1542)
D	6	Nylon bolts M3 x 12mm (1541)	J	10	Nylon hex nuts 3mm (1540)
E	1	UltiController FRONT (1095)	K	1	button (1129)
F	1	UltiController window (1522)	L	2	UltiController PCB Connection Cable (1171)

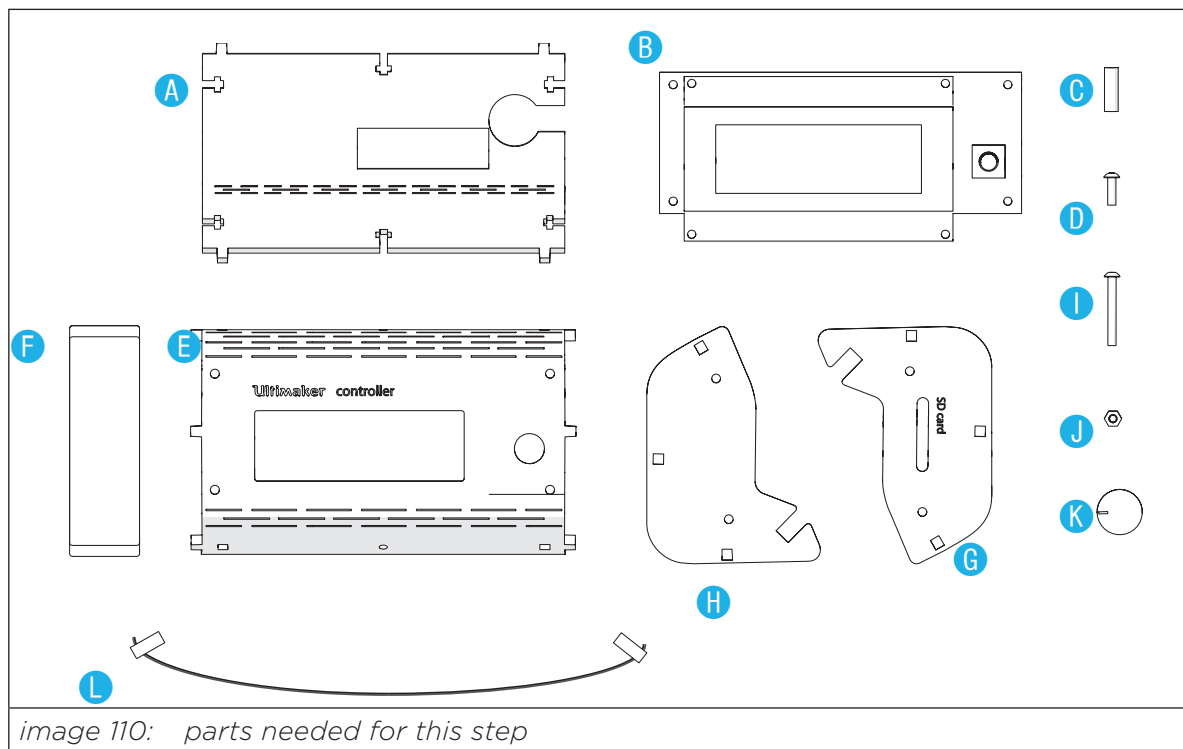

To assemble the UltiController, perform the following actions.

1. Remove the foil from the display V1.0 (if present).
2. Remove the protective sticker from the piezo speaker (if present).
3. Remove the foil from the acrylic window.
4. Place UltiController FRONT facing down and place the acrylic window in the cutout.
5. Attach the display to the UltiController FRONT, see image 111.
Use four bolts M3 x 25mm, four tube spacers and four hex nuts 3mm.



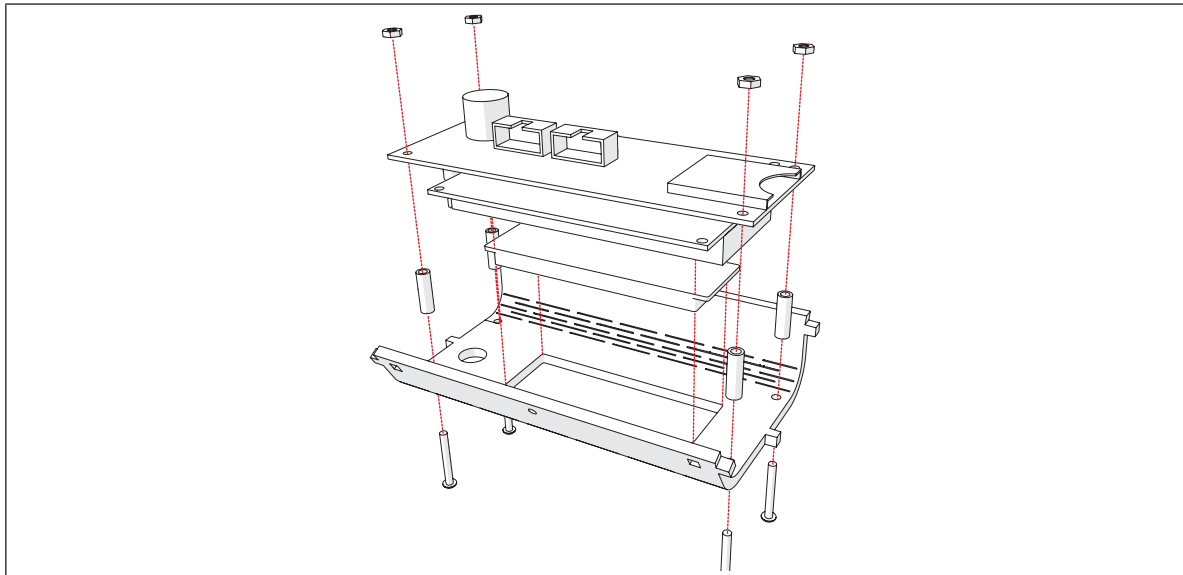

image 111: mounting the display v 1.0 to the UltiController FRONT

(for action 4-8 see image 112)

6. Turn the controller on its back.
7. Plug both of the PCB connector cables into the connectors.
- i** Tip: write numbers on the cables to remember in which connector it's placed.
8. Place six hex nuts 3mm inside the slots of the UltiController BACK.
Tip: Use tape to keep the hex nuts 3mm in position.
9. Attach the UltiController BACK onto the UltiController FRONT,
Use two bolts M3 x 12mm at the long sides.
10. Attach the side parts.
Use two bolts M3 x 12mm for every side.

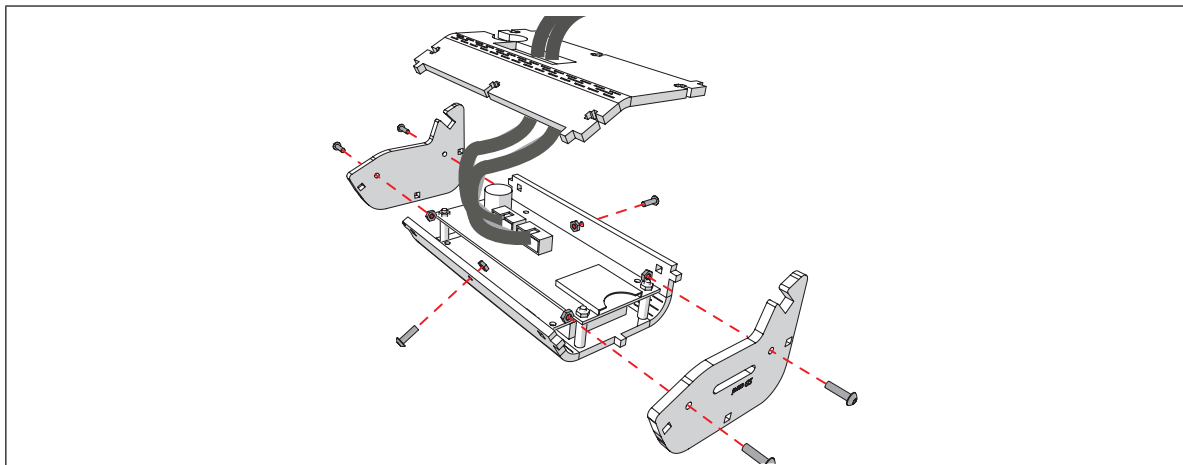

image 112: mounting the back plate and the side parts

11. Put the button in place, see image 113.



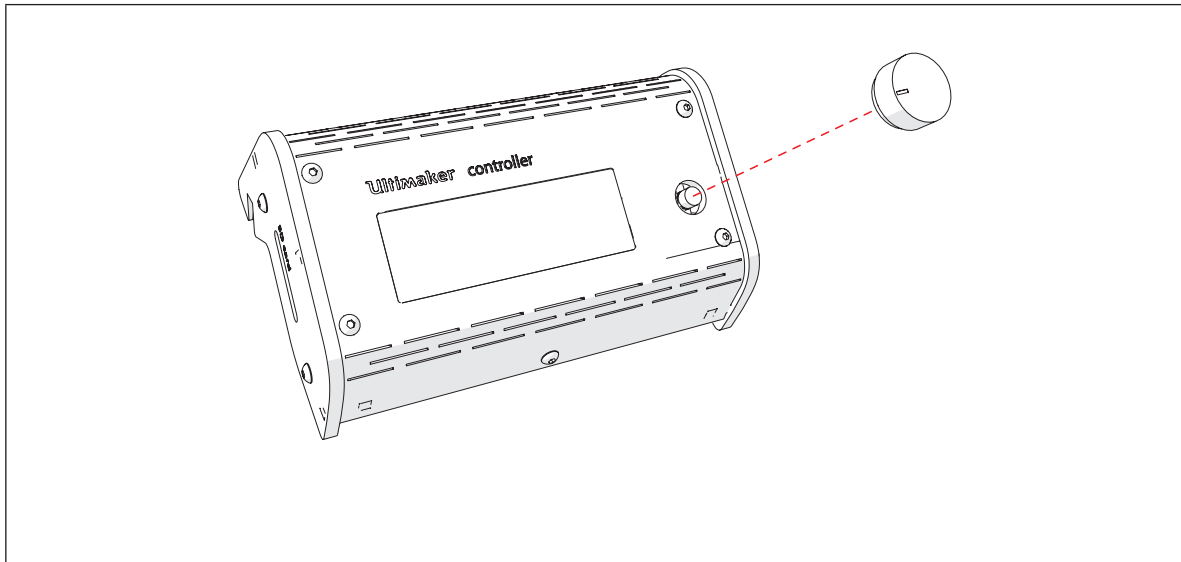

image 113: placing the button

6.6.2. Step 2: connecting the controller

To connect the UltiController, perform the following actions.

1. Guide the cables through the hole in the BOTTOM panel.
2. Connect the cable
3. Put the UltiController on the lower part of the FRONT panel.

i If you find it hard to reach the connectors you can remove the cover plate.

i **Notice:** check for information about firmware updates and usage in the Software setup guide.



6.6.3. Step 3: checking and aligning the top-Z limit switch

i **Notice:** this is the MOST important end-stop of the machine. It's important that the starting height is about 0.1 mm above the heated bed

To check and align the top-Z limit switch, perform the following actions:
(for action 1-15 see image 1114)

1. Loosen the bolts slightly of the top-Z limit switch
You must be able to move the switch up and down.
2. Turn the lead screw to elevate the glass platform until the nozzle of the extrusion head almost touches the platform.

i **Notice:** It must be possible to move ONE A4 paper between the nozzle and the Glass platform. TWO A4 papers must NOT be possible.

3. Lower the limit switch.
4. Attach one side of the limit switch.
5. Move the other side.

i **Notice:** the limit switch will rotate a little.

6. Rotate the switch till you hear a click. The switch is now closed.
7. Screw the bolts tight.

i **Notice:** the switch shouldn't move anymore.

i **Notice:** when you are using the control software for the first time, test the response to the limit switches. Especially the top-Z limit switch

8. Turn the machine on and use the Auto home function on the controller to check the alignment of the stop. adjust if necessary.
9. Move the extrusion head to the FRONT LEFT corner. See image 110
10. Turn the thumbscrew until the Glass platform touches the nozzle.
11. Move the the extrusion head from the FRONT LEFT to the FRONT RIGHT corner.
12. Turn the thumbscrew until the Glass platform touches the nozzle.
13. Move the the extrusion head rom the FRONT RIGHT to the BACK middle.
14. Turn the thumbscrew until the Glass platform touches the nozzle.
15. Repeat the steps above to check if the alignment is correct.



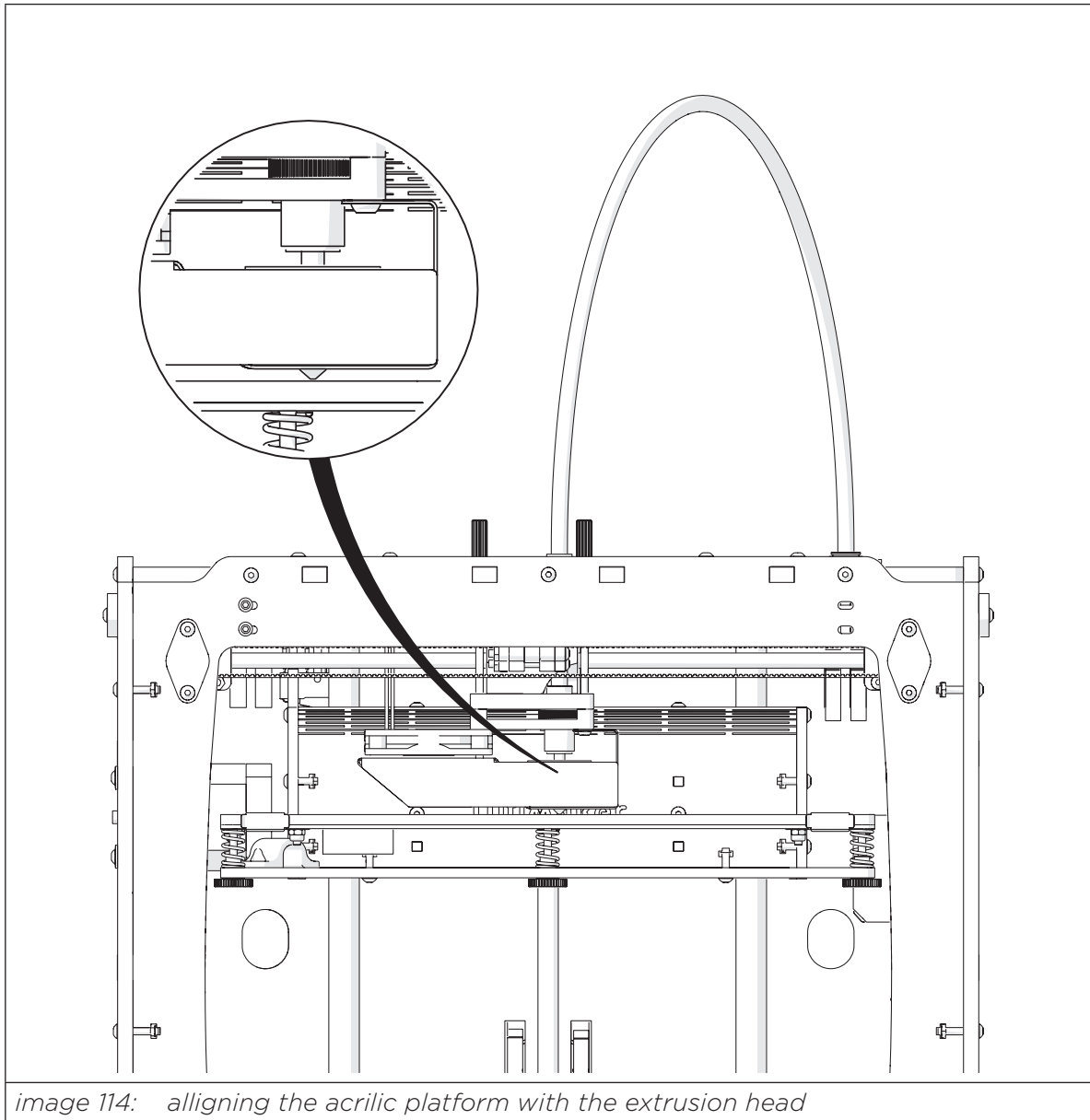

image 114: aligning the acrylic platform with the extrusion head



7 Usage of the Ultimaker Original+

7.1

USING THE ULTIMAKER ORIGINAL+ FOR THE FIRST TIME

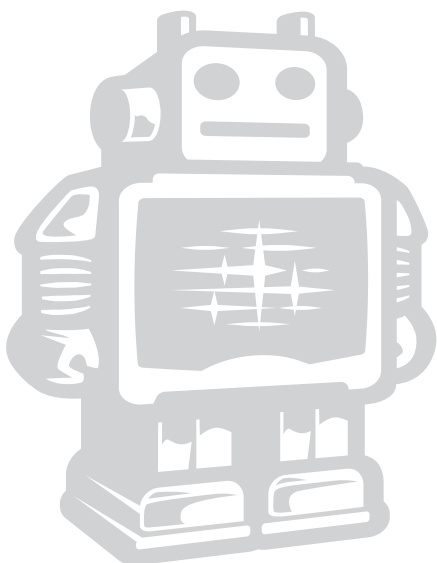

We recommend you to use supplied software, but feel free to use different types of programs if you feel like you are up to it, or just simply disagree. Playful experimenting and innovating is what made Ultimaking B.V. to what it is today.

We also supply a user manual where you can find a more detailed guide how to handle the machine.

There are 2 different types of software that you will need to get your Ultimaker printing. Some software have these combined, others do not.

First you need a slicer to create the file that contains all the parameters of a print, called the Gcode. Secondly you need software to send this Gcode to your Ultimaker. In the beginning you most likely will download a file from the world wide web to print. Plenty of these files can be found on websites like www.youmagine.com.

One of the files that is printable is called a STL.

7.1.1. Installing the Ultimaker Original + firmware.

When you first start the machine, the firmware might not be correctly installed for this board. To install the correct firmware follow these steps.

1. Go to our website menu 'community'
2. 'download' for the latest version of Cura.
3. Open Cura
4. Go to Expert > Install default Marlin Firmware.

7.1.2. Slicer software

As a slicer we can recommend you to use:

-Cura

The basic idea of slicing is that it converts a printable file (STL) to a code that contains all the information to create your print. We will take you along to create a Gcode, to print with PLA.

Cura

1. Go to our website menu 'community'
2. 'download' for the latest version of Cura.
3. Open Cura
4. Go to Expert > Install default Marlin Firmware.
5. Use the default STL



-
6. Go to Tools > Switch to Quickprint.
 7. Choose High Quality Print, and PLA.
 8. If asked, enter the diameter of your filament.
- i** **Notice:** The filament should be approximately 2.85mm, but it may vary 0.7mm.
- i** **Notice:** If you do not have digital calipers, enter a number between 2.85-2.90mm.
- i** **Notice:** You do not have to tick 'Print Support Structure'.

Is the Ultimaker Original+ connected with the computer, go to action 9.

If it's not. Go to action 10.

Via the computer

9. If the Ultimaker is connected with the computer, click 'Print'.

Via the UltiController

1. To print it with the UltiController, save your gcode to SD card for example.
2. Place the SD card into the SD slot on the LEFT of your UltiController.
3. On the screen it should say, Card inserted.
4. Press the navigation wheel, go to card menu and select the file you want to print.
5. Your Ultimaker will go 'home' heat up to the RIGHT temperature and calculate a path and start to print.



8 Anex

8.1

SAFETY GUIDELINES FOR THE ULTIMAKER ORIGINAL +



Safety guidelines

Because the Ultimaker original is a DIY 3D printer, we cannot guarantee the build quality. Subsequently, we cannot guarantee complete compliance with the CE regulations.

However, we have designed the new Ultimaker original with safety in mind and ran a fully assembled machine through all the tests necessary to make sure it passed every CE mark regulation applicable. A list of all the test standards is shown below.

Standard:

EN ISO 12100: 2010
EN 55022: 2011 Class A
EN 55024: 2010
EN 61000-4-2: 2009
EN 61000-4-3: 2006
+ A1: 2008 + A2: 2010
EN 61000-4-4: 2004
EN 61000-4-5: 2006
EN 61000-4-6: 2009
61000-4-11: 2004

Title:

Safety of machinery
Radiated Emissions Class A
Radiation immunity
Electrostatic discharge
Radio-Frequency, Electromagnetic Field
Electrical Fast Transient
Immunity to surges
Conducted Radio-frequency EN
Voltage dips and interruptions

So if you assemble your Ultimaker original while closely following the building instructions, it should comply with the CE mark standard.

Electromagnetic compatibility (EMC)

The EMC test report on the fully assembled Ultimaker original is available on request at info@ultimaker.com

Electrical safety

The Ultimaker original operates on 24 volts (Extra-low-voltage) and is therefore outside the scope of the low-voltage directive. The power supply meets all CE mark regulations and is protected against short-circuit, overload, over voltage and over temperature. For more information concerning electrical safety aspects we refer you to the Mean Well EC-Conformity Declaration for the GS220AX power adaptors.

 Always unplug the printer before maintenance or modifications.













Mechanical safety

The Ultimaker original contains many moving parts, but the stepper motors do not have enough power to cause serious injuries and moving gears have been covered. Still, it is advised to only reach in the machine when it is turned off.

 Always unplug the printer before maintenance or modifications.

Risk of burns

There is a potential risk of burns, as the print-head can reach temperatures of up to 260°C and the heated bed of up to 120°C. The nozzle of the print-head is mostly surrounded by an aluminum cover to prevent contact, but still we advise against reaching in the machine when the print-head and/or heated bed are hot.

 Always let the printer cool down for at least 30 minutes before maintenance or modifications.

Health

The Ultimaker original is designed to print with PLA and ABS filaments. The use of other materials is at your own risk.

When printing ABS, small concentrations of Styrene vapor can be released. This can (in some cases) cause headaches, fatigue, dizziness, confusion, drowsiness, malaise, difficulty in concentrating, and a feeling of intoxication. Therefore good ventilation is required, and long term exposure should be avoided. It is advisable to use a fume hood (with active carbon filtering for ductless extraction). Fume extraction is mandatory for use in offices, classrooms and alike.

Printing pure PLA is considered safe, although good ventilation is still advised for possible unknown vapors released from coloring dyes in colored PLA.

 Only use your printer in a well-ventilated area.



General safety information

The Ultimaker original is not intended for use by persons (including children) with reduced physical and/or mental capabilities, or lack of experience and knowledge, unless they have been given supervision or instruction concerning the use of the appliance by a person responsible for their safety.

Children should be under constant supervision when using the printer.

The above information is believed to be correct but does not purport to be all inclusive and shall be used only as a guide.

The conditions or methods used for assembling, handling, storage, use or disposal of the device are beyond our control and may be beyond our knowledge. For this and other reasons, we do not assume responsibility and expressly disclaim liability for loss, injuries, damage, or expense arising out of or in any way connected with the assembly, handling, storage, use or disposal of the product

The information in this document was obtained from sources which we believe are reliable.

However, the information is provided without any warranty, express or implied, regarding its correctness.





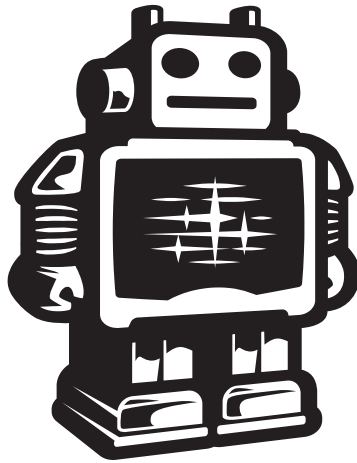

Ultimaker

The fast, easy to use, Open-source 3D printer

